

Integrating Concurrency Control and Energy Management in Device Drivers

Kevin Klues, Vlado Handziski, Chenyang Lu, Adam Wolisz,
David Culler, David Gay, and Philip Levis

Overview

- **Concurrency Control:**
 - ◆ Concurrency of I/O operations alone, not of threads in general
 - ◆ Synchronous vs. Asynchronous I/O
- **Energy Management:**
 - ◆ Power state of devices needed to perform I/O operations
 - ◆ Determined by pending I/O requests using Asynchronous I/O

Overview

- **Concurrency Control:**
 - ◆ Concurrency of I/O operations alone, not of threads in general
 - ◆ Synchronous vs. Asynchronous I/O
- **Energy Management:**
 - ◆ Power state of devices needed to perform I/O operations
 - ◆ Determined by pending I/O requests using Asynchronous I/O

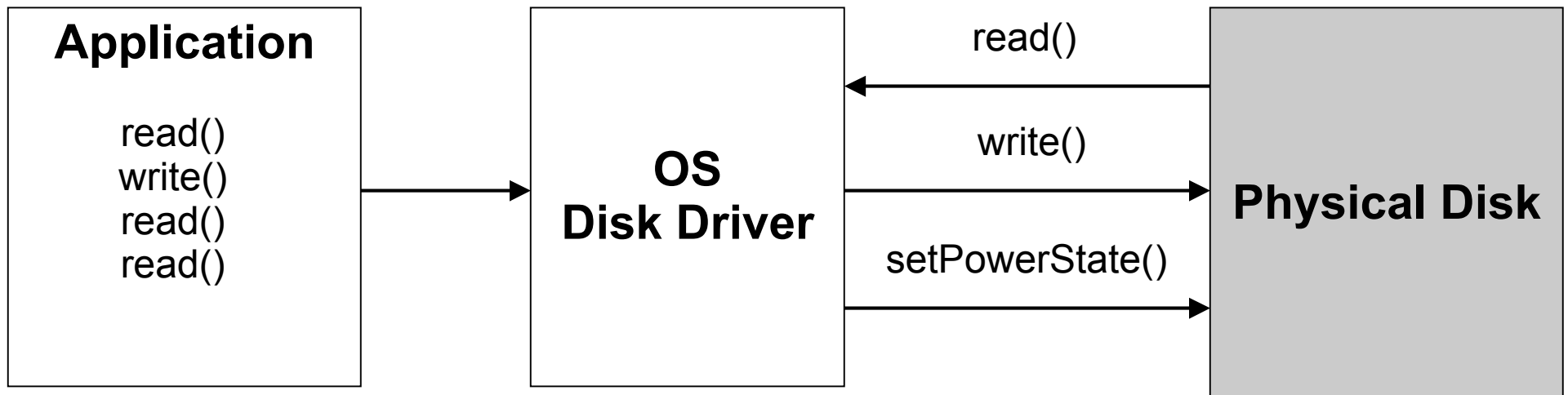

Overview

- **Concurrency Control:**
 - ◆ Concurrency of I/O operations alone, not of threads in general
 - ◆ Synchronous vs. Asynchronous I/O
- **Energy Management:**
 - ◆ Power state of devices needed to perform I/O operations
 - ◆ Determined by pending I/O requests using Asynchronous I/O

The more workload information an application can give the OS, the more energy it can save when scheduling that workload

Outline

- **Background Information**
- Platform and Application
- Driver architecture
- Evaluation
- Conclusion

Motivation

- Difficult to manage energy in traditional OSs
 - ◆ Hard to tell OS about future application workloads
 - ◆ All logic pushed out to the application
 - ◆ API extensions for hints?

Existing OS Approaches

- Dynamic CPU Voltage Scaling
 - ◆ Vertigo - Application workload classes
 - ◆ Grace OS - Explicit realtime deadlines
- Disk Spin Down
 - ◆ Coop-IO - Application specified timeouts

Existing OS Approaches

- Dynamic CPU Voltage Scaling
 - ◆ Vertigo - Application workload classes
 - ◆ Grace OS - Explicit realtime deadlines
- Disk Spin Down
 - ◆ Coop-IO - Application specified timeouts

Saving energy is a complex process

Existing OS Approaches

- Dynamic CPU Voltage Scaling
 - ◆ Vertigo - Application workload classes
 - ◆ Grace OS - Explicit realtime deadlines
- Disk Spin Down
 - ◆ Coop-IO - Application specified timeouts

**Saving energy is a complex process
A little application knowledge can help us alot**



Sensor Networks

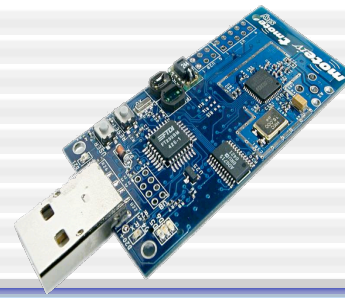

- Domain in need of unique solution to this problem
 - ◆ Harsh energy requirements
 - ◆ Very small source of power (2AA batteries)
 - ◆ Must run unattended from months to years



Sensor Networks

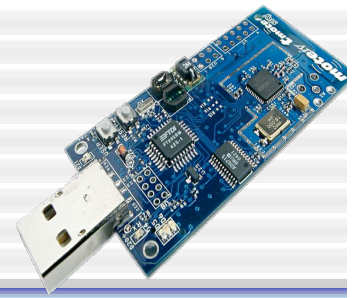

- Domain in need of unique solution to this problem
 - ◆ Harsh energy requirements
 - ◆ Very small source of power (2AA batteries)
 - ◆ Must run unattended from months to years
- First generation sensornet OSEs (TinyOS, Contiki, Mantis, ...)
 - ◆ Push all energy management to the application
 - ◆ Optimal energy savings at cost of application complexity

ICEM: Integrated Concurrency and Energy Management

- A device driver architecture that automatically manages energy
 - ◆ Implemented in TinyOS 2.0 -- all drivers follow it
 - ◆ Introduces *Power Locks*, split-phase locks with integrated energy and configuration management
 - ◆ Defines three classes of drivers: dedicated, shared, virtualized
 - ◆ Provides a component library for building drivers

ICEM: Integrated Concurrency and Energy Management

- A device driver architecture that automatically manages energy
 - ◆ Implemented in TinyOS 2.0 -- all drivers follow it
 - ◆ Introduces *Power Locks*, split-phase locks with integrated energy and configuration management
 - ◆ Defines three classes of drivers: dedicated, shared, virtualized
 - ◆ Provides a component library for building drivers
- Advantages of using **ICEM**
 - ◆ Energy efficient – At least 98.4% as hand-tuned implementation
 - ◆ Reduces code complexity – 400 vs. 68 lines of code
 - ◆ Enables natural decomposition of applications

Outline

- Introduction and Motivation
- **Platform and Application**
- ICEM architecture
- Evaluation
- Conclusion

The Tmote Platform

- Six major I/O devices
- Possible Concurrency
 - ◆ I²C, SPI, ADC
- Energy Management
 - ◆ Turn peripherals on only when needed
 - ◆ Turn off otherwise

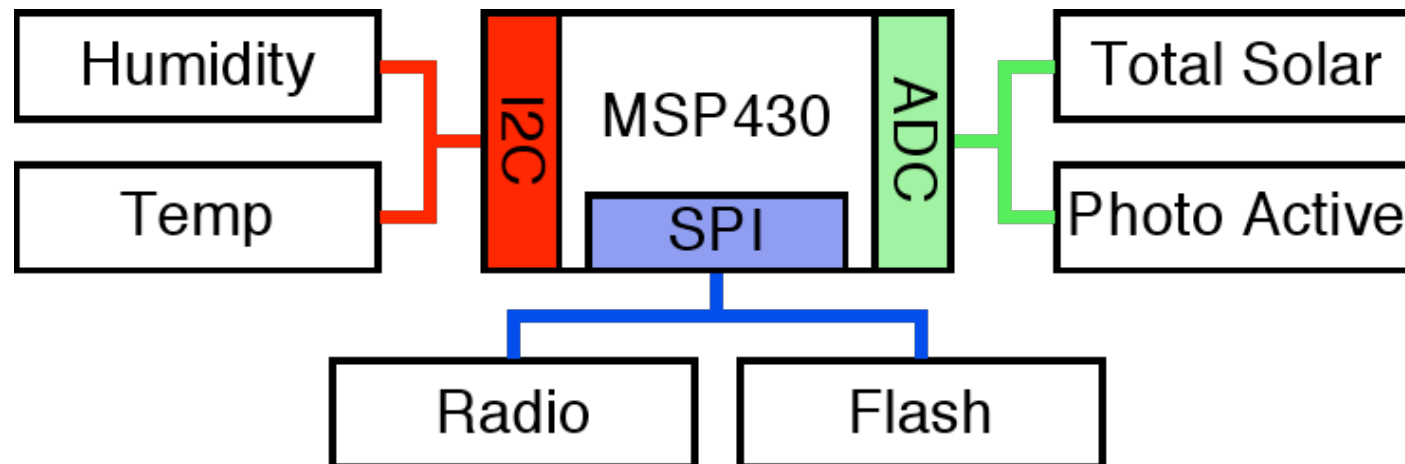
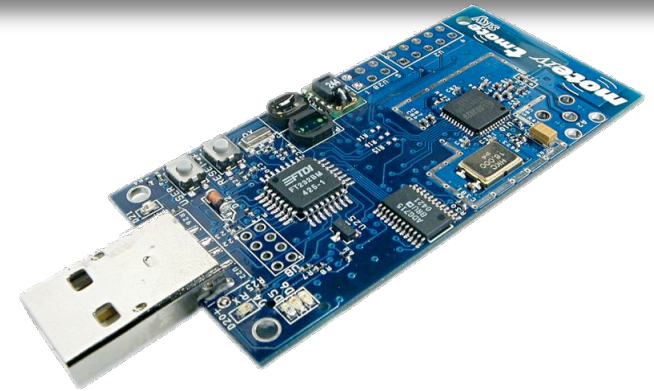

Representative Logging Application

Producer

Every 5 minutes:

Write prior samples
Sample photo active
Sample total solar
Sample temperature
Sample humidity

Flash

Consumer

Every 12 hours:

For all new entries:
Send current sample
Read next sample

Sensors

Radio

Representative Logging Application

Producer

Every 5 minutes:

Write prior samples
Sample photo active
Sample total solar
Sample temperature
Sample humidity

Flash

Consumer

Every 12 hours:

For all new entries:
Send current sample
Read next sample

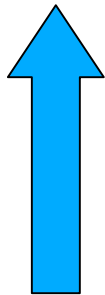

Sensors

Radio

Representative Logging Application

Producer

Every 5 minutes:

Write prior samples
Sample photo active
Sample total solar
Sample temperature
Sample humidity

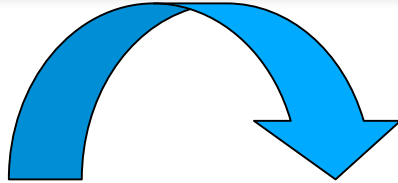

Flash

Consumer

Every 12 hours:

For all new entries:
Send current sample
Read next sample

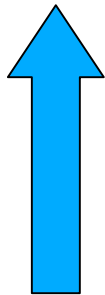

Sensors

Radio

Representative Logging Application

Producer

Every 5 minutes:

Write prior samples
Sample photo active
Sample total solar
Sample temperature
Sample humidity

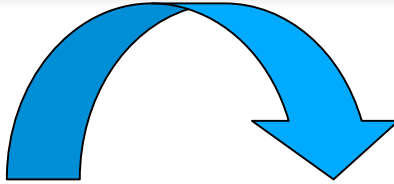

Flash

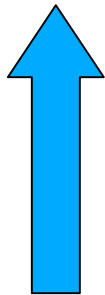
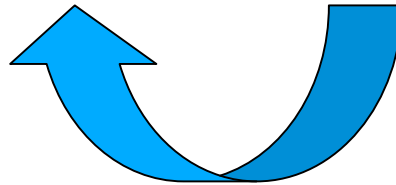

Sensors

Consumer

Every 12 hours:

For all new entries:
Send current sample
Read next sample

Radio

Representative Logging Application

Producer

Every 5 minutes:

Write prior samples
Sample photo active
Sample total solar
Sample temperature
Sample humidity

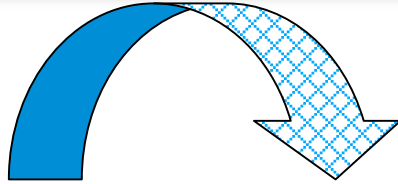

Flash

Consumer

Every 12 hours:

For all new entries:
Send current sample
Read next sample

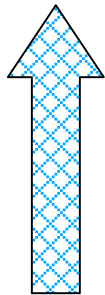
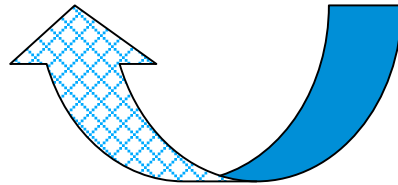

Sensors

Radio

Representative Logging Application

Producer

Every 5 minutes:

Write prior samples
Sample photo active
Sample total solar
Sample temperature
Sample humidity

Consumer

Every 12 hours:

For all new entries:
Send current sample
Read next sample

Flash

Sensors

Radio

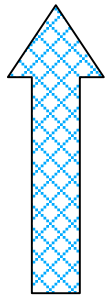
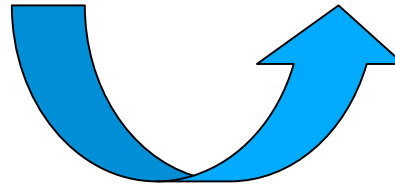
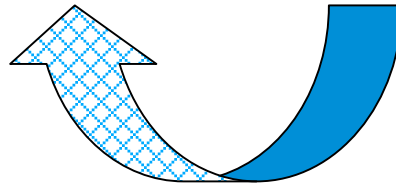
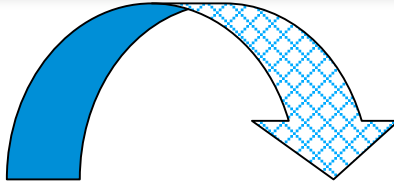

Representative Logging Application

Producer

Every 5 minutes:

Write prior samples
Sample photo active
Sample total solar
Sample temperature
Sample humidity

Consumer

Every 12 hours:

For all new entries:
Send current sample
Read next sample

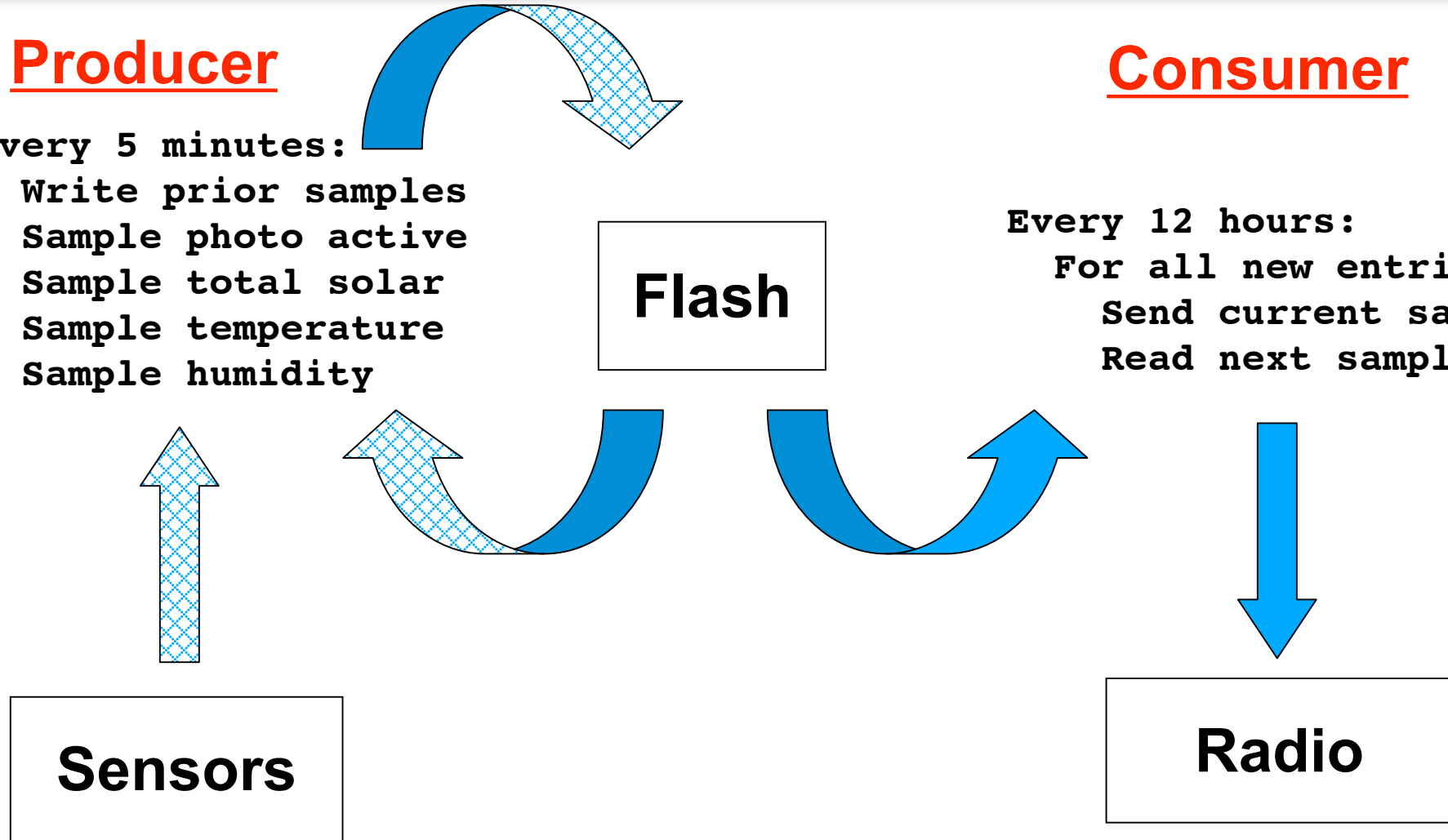

Representative Logging Application

Producer

Every 5 minutes:

Write prior samples
Sample photo active
Sample total solar
Sample temperature
Sample humidity

Consumer

Every 12 hours:

For all new entries:
Send current sample
Read next sample

Flash

Sensors

Radio

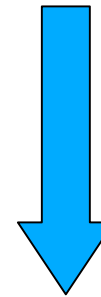
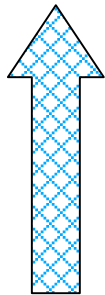
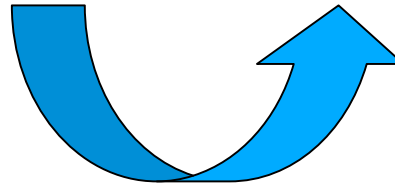
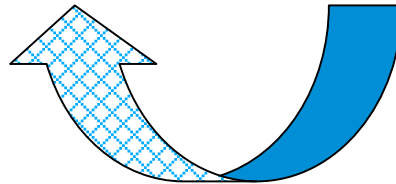
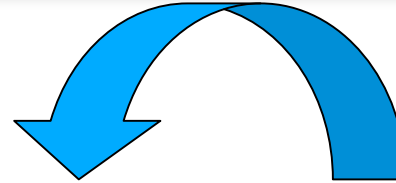
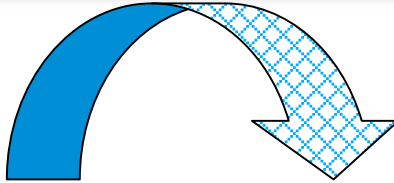

Representative Logging Application

Producer

Every 5 minutes:

Write prior samples
Sample photo active
Sample total solar
Sample temperature
Sample humidity

Consumer

Every 12 hours:

For all new entries:
Send current sample
Read next sample

Flash

Sensors

Radio

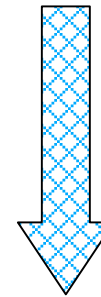
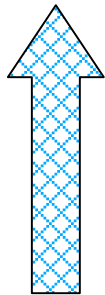
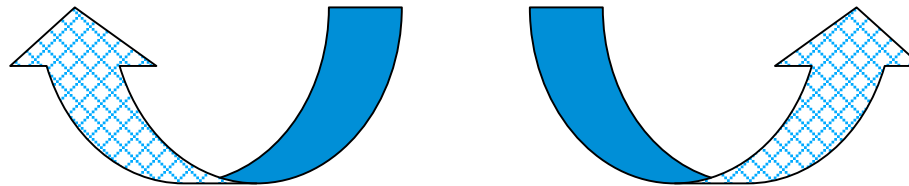
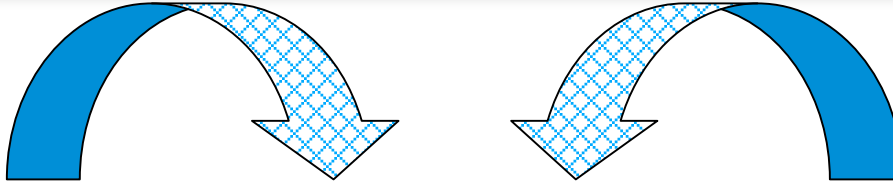

Code Complexity

Hand-Tuned Application

Code Complexity

Hand-Tuned Application

Every 5 minutes:

Turn on SPI bus

Turn on flash chip

Turn on voltage reference

Turn on I²C bus

Log prior readings

Start humidity sample

Wait 5ms for log

Turn off flash chip

Turn off SPI bus

Wait 12ms for vref

Turn on ADC

Start total solar sample

Wait 2ms for total solar

Start photo active sample

Wait 2ms for photo active

Turn off ADC

Turn off voltage reference

Wait 34ms for humidity

Start temperature sample

Wait 220ms for temperature

Turn off I²C bus

Code Complexity

Hand-Tuned Application

Every 5 minutes:

Turn on SPI bus

Turn on flash chip

Turn on voltage reference

Turn on I²C bus

Log prior readings

Start humidity sample

Wait 5ms for log

Turn off flash chip

Turn off SPI bus

Wait 12ms for vref

Turn on ADC

Start total solar sample

Wait 2ms for total solar

Start photo active sample

Wait 2ms for photo active

Turn off ADC

Turn off voltage reference

Wait 34ms for humidity

Start temperature sample

Wait 220ms for temperature

Turn off I²C bus

Code Complexity

Hand-Tuned Application

Every 5 minutes:

Turn on SPI bus

Turn on flash chip

Turn on voltage reference

Turn on I²C bus

Log prior readings

Start humidity sample

Wait 5ms for log

Turn off flash chip

Turn off SPI bus

Wait 12ms for vref

Turn on ADC

Start total solar sample

Wait 2ms for total solar

Start photo active sample

Wait 2ms for photo active

Turn off ADC

Turn off voltage reference

Wait 34ms for humidity

Start temperature sample

Wait 220ms for temperature

Turn off I²C bus

Code Complexity

Hand-Tuned Application

Every 5 minutes:

Turn on SPI bus
Turn on flash chip
Turn on voltage reference
Turn on I²C bus

Log prior readings

Start humidity sample

Wait 5ms for log

Turn off flash chip

Turn off SPI bus

Wait 12ms for vref

Turn on ADC

Start total solar sample

Wait 2ms for total solar

Start photo active sample

Wait 2ms for photo active

Turn off ADC

Turn off voltage reference

Wait 34ms for humidity

Start temperature sample

Wait 220ms for temperature

Turn off I²C bus

ICEM Application

Every 5 minutes:

Log prior readings
sample humidity
sample total solar
sample photo active
sample temperature

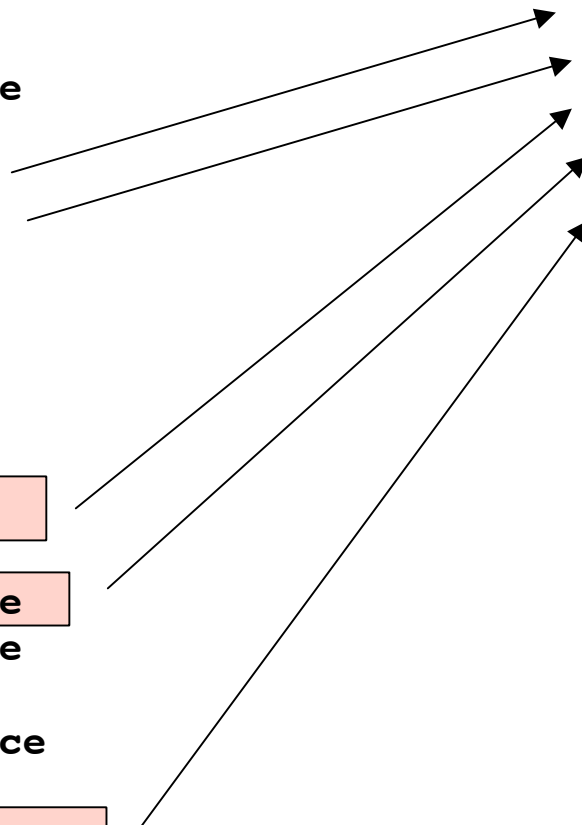

Outline

- Introduction and Motivation
- Platform and Application
- **ICEM architecture**
- Evaluation
- Conclusion

Split-Phase I/O Operations

- Split-phase I/O operations
 - ◆ Implemented within a single thread of control
 - ◆ Application notified of I/O completion through direct upcall
 - ◆ Driver given workload information before returning control
 - ◆ Example: `read()` \Rightarrow `readDone()`

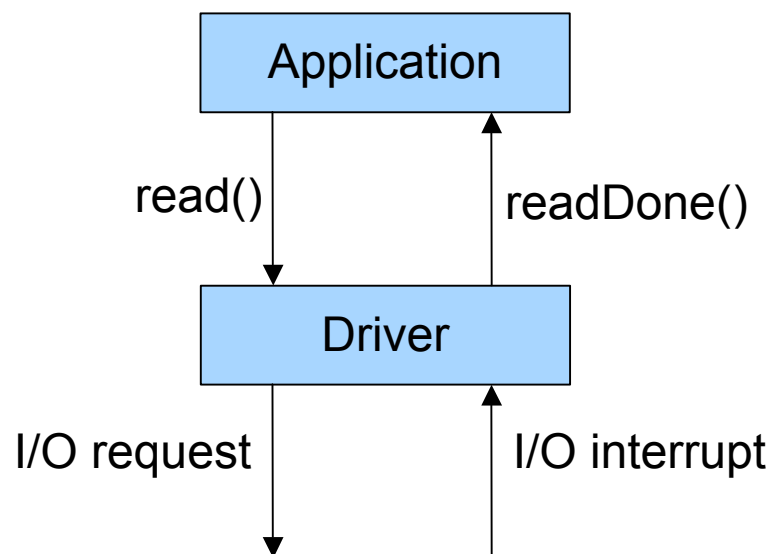

```
void readDone(uint16_t val) {  
    next_val = val;  
    read();  
}
```

ICEM Architecture

- Defines three classes of drivers
 - ◆ Virtualized – provide only functional interface
 - ◆ Dedicated – provide functional and power interface
 - ◆ Shared – provide functional and lock interface

Virtualized Device Drivers

- Provide only a **Functional** interface
- Assume multiple users
- **Implicit** concurrency control through buffering requests
- **Implicit** energy management based on pending requests
- Implemented for higher-level services that can tolerate longer latencies

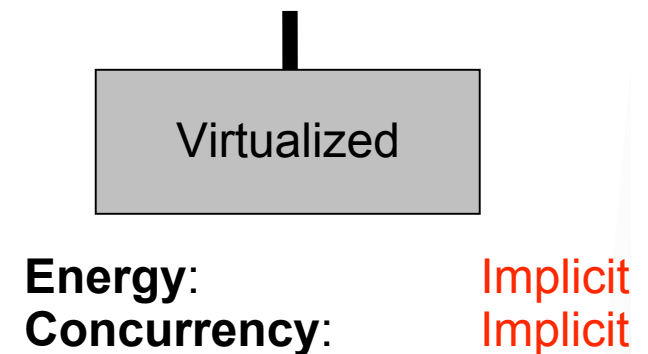

Dedicated Device Drivers

- Provide **Functional** and **Power Control** interfaces
- Assume a single user
- **No** concurrency control
- *Explicit* energy management
- Low-level hardware and bottom-level abstractions have a dedicated driver

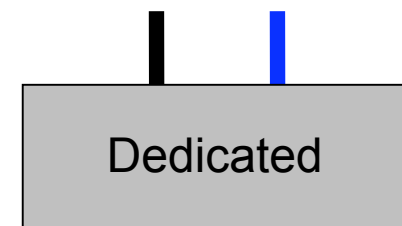

Energy: **Implicit**
Concurrency: **None**

Shared Device Drivers

- Provide **Functional** and **Lock** interfaces
- Assume multiple users
- **Explicit** concurrency control through Lock request
- **Implicit** energy management based on pending requests
- Used by users with stringent timing requirements

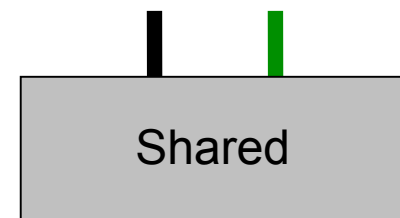

Energy: **Implicit**
Concurrency: **Explicit**

ICEM Architecture

- Defines three classes of drivers
 - ◆ Virtualized – provide only functional interface
 - ◆ Dedicated – provide functional and power interface
 - ◆ Shared – provide functional and lock interface
- *Power Locks*, split-phase locks with integrated energy and configuration management

Power Locks

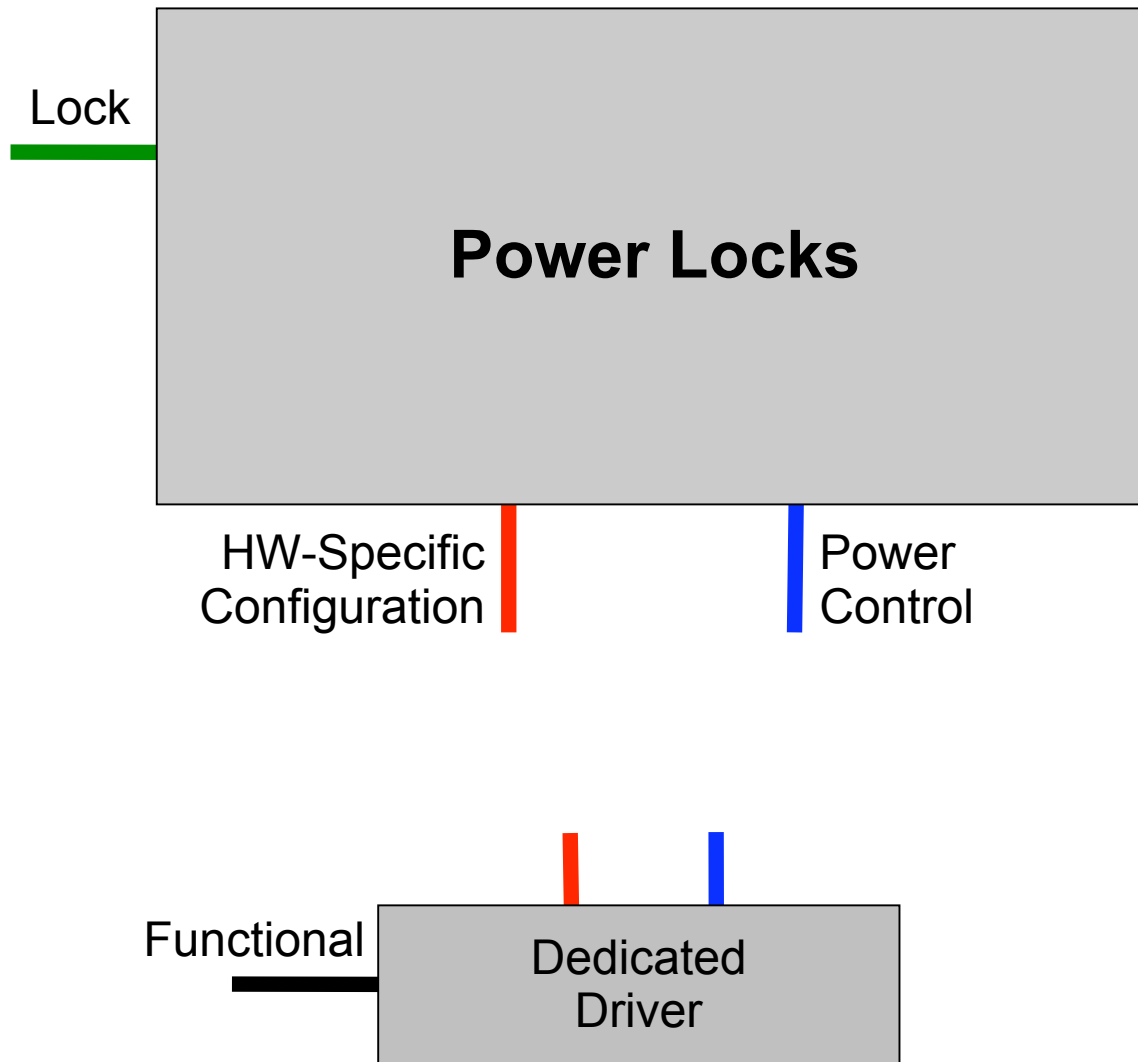

Power Locks

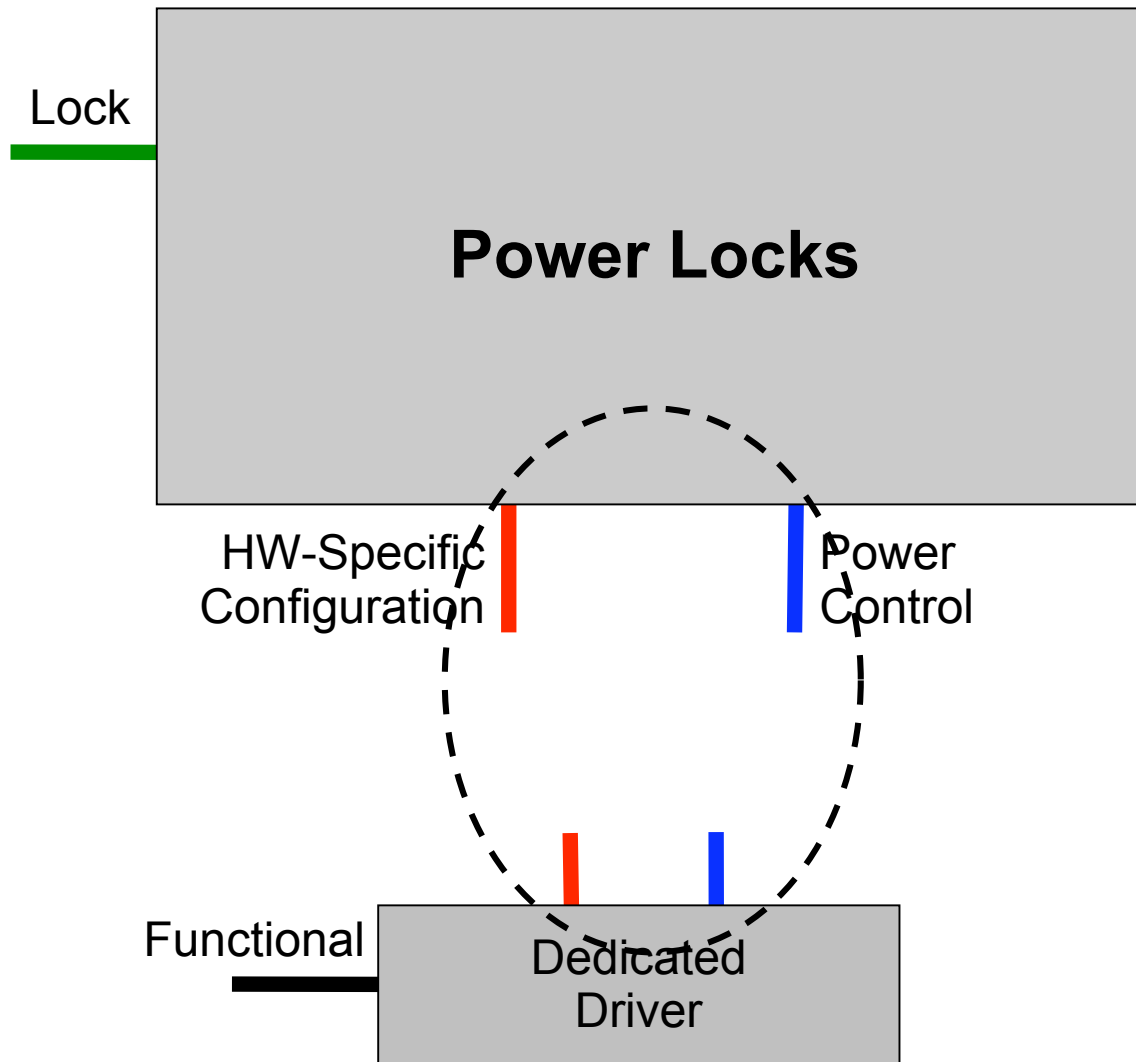

Power Locks

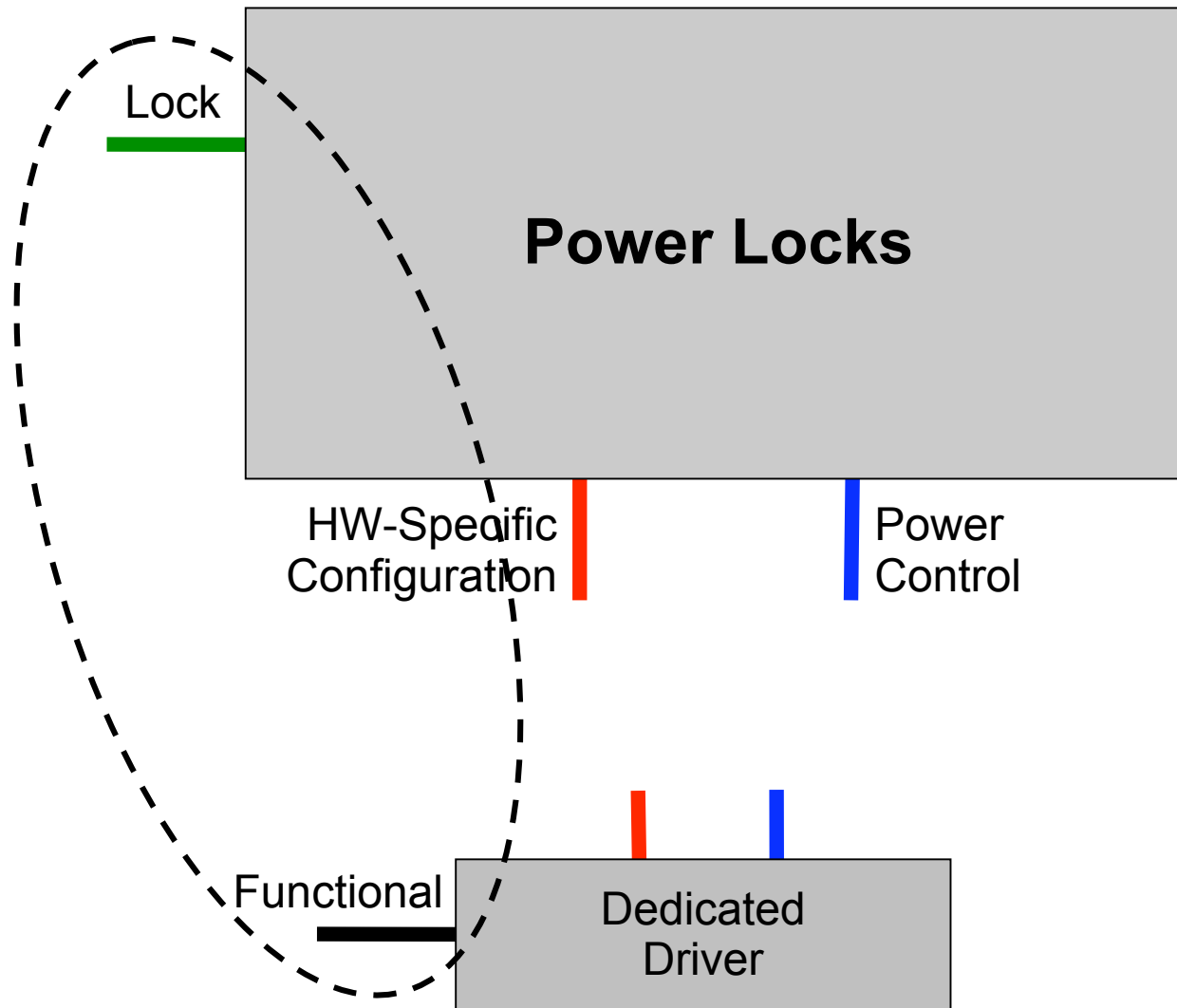

Power Locks

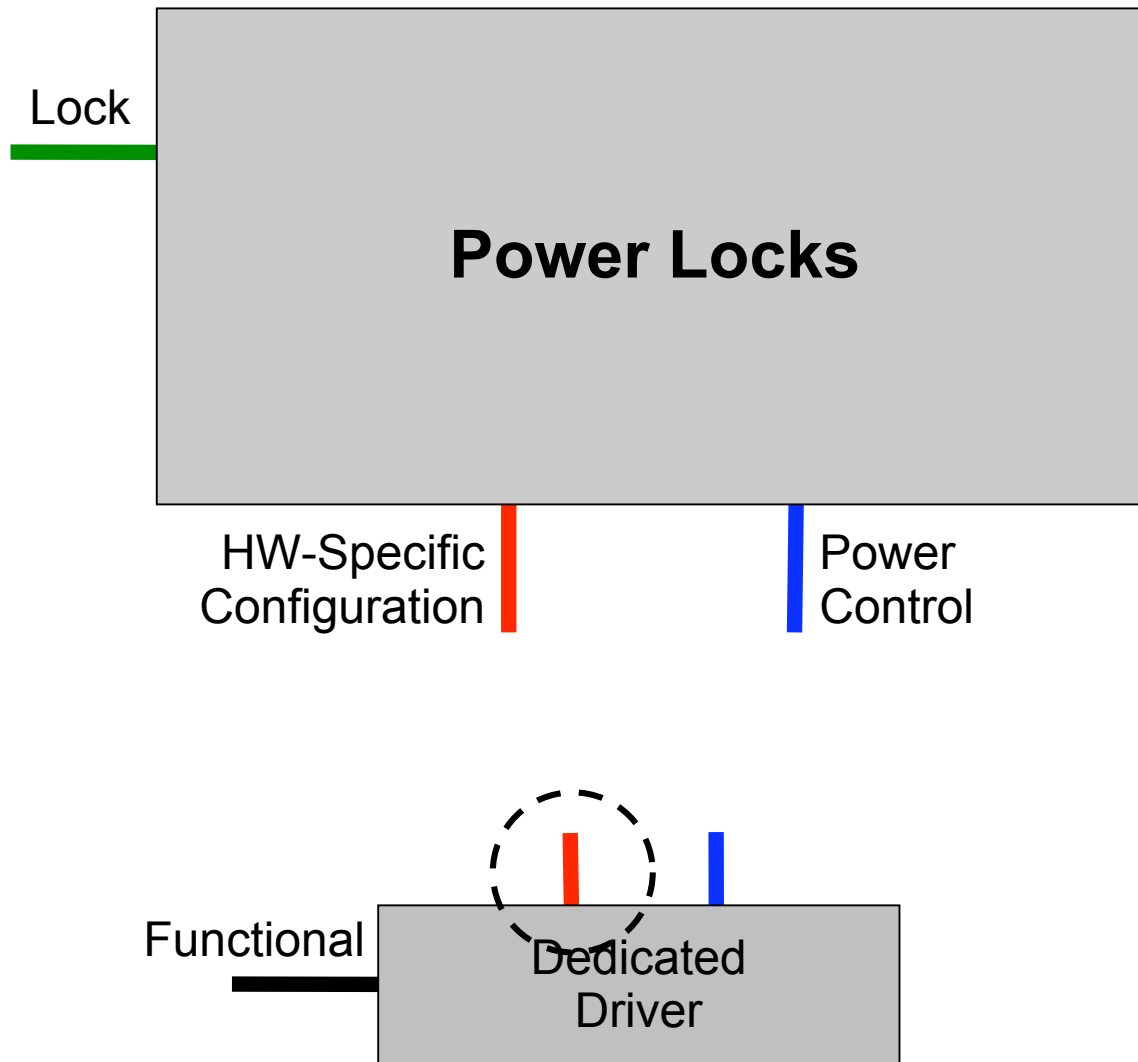

Power Locks

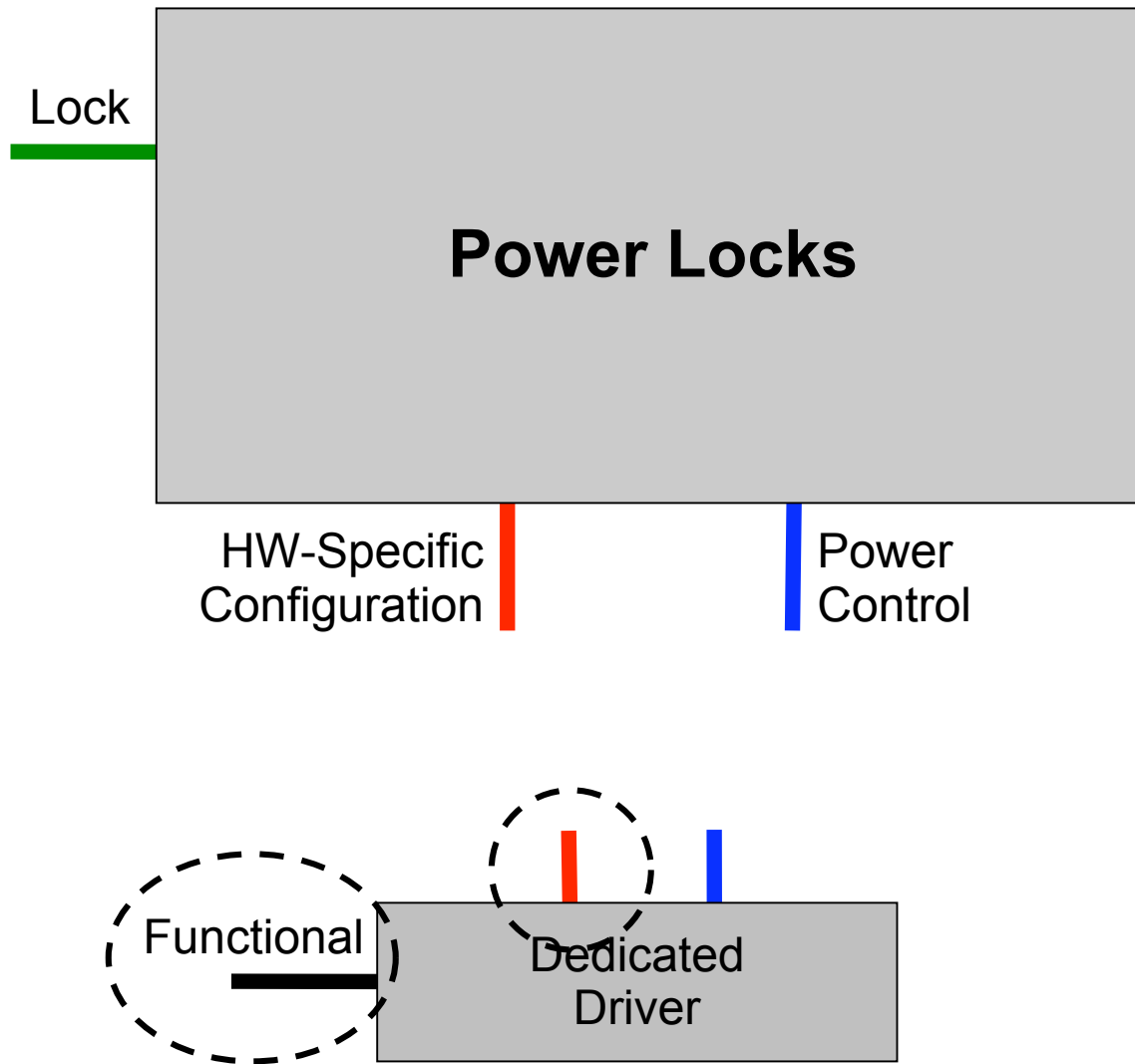

Power Locks

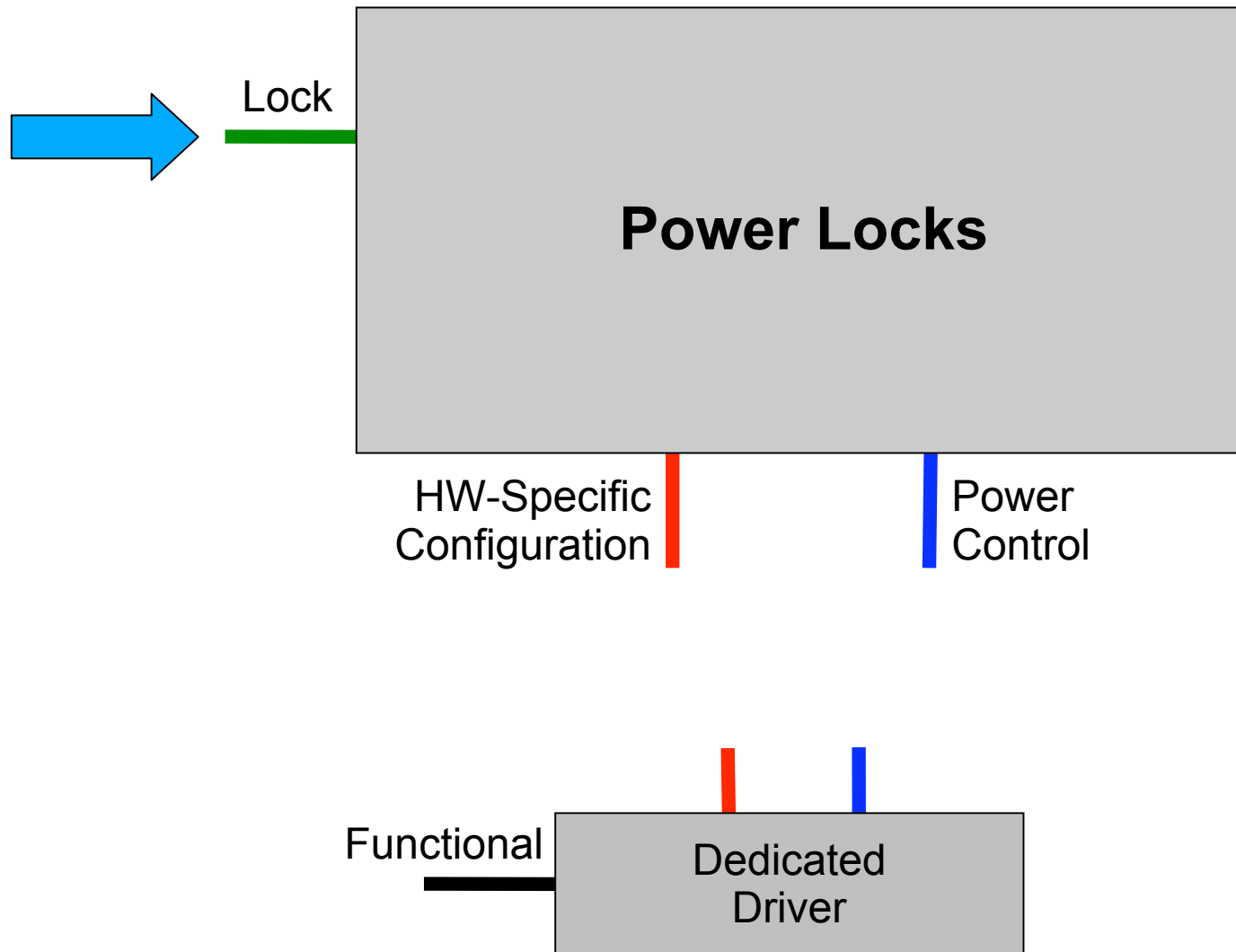

Power Locks

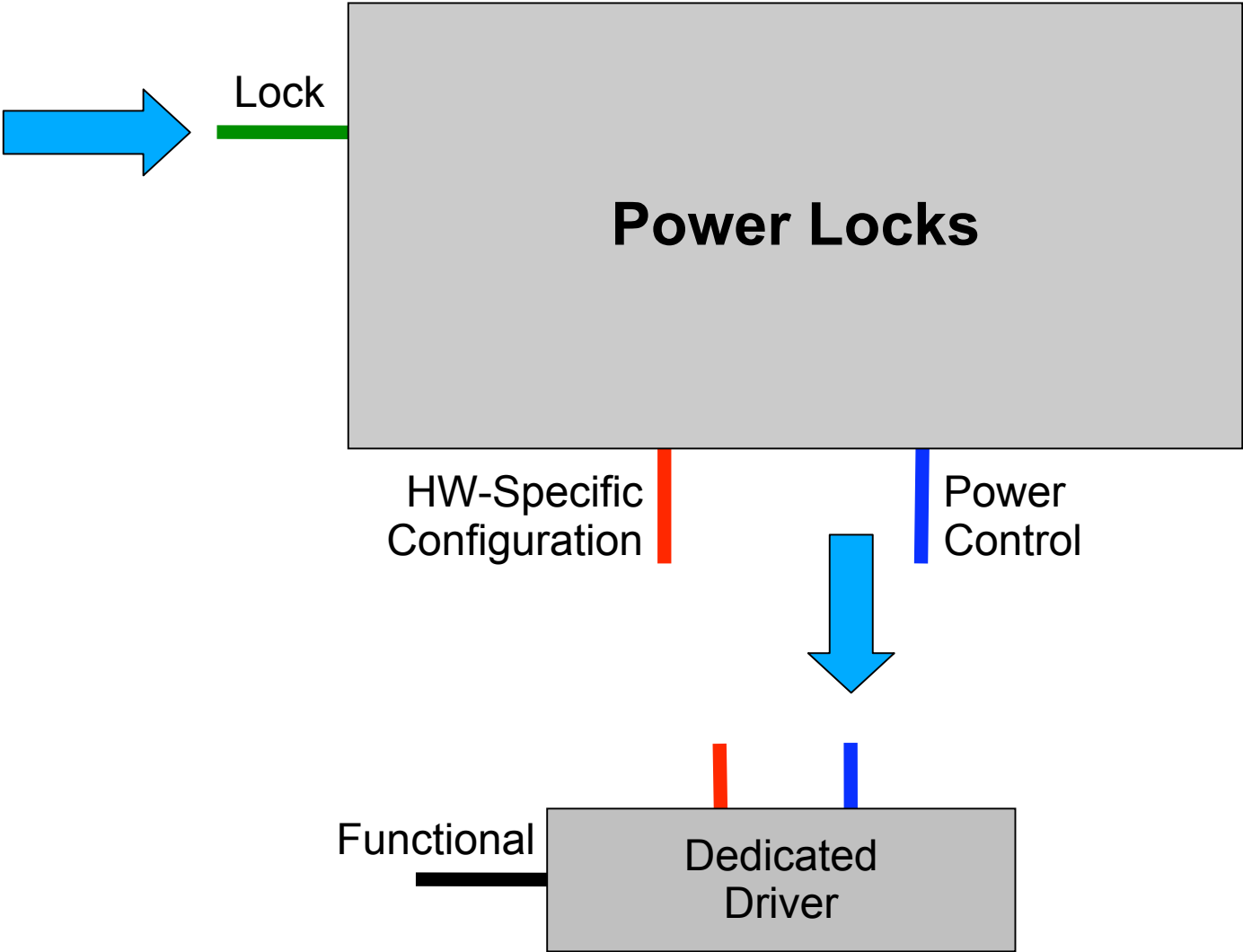

Power Locks

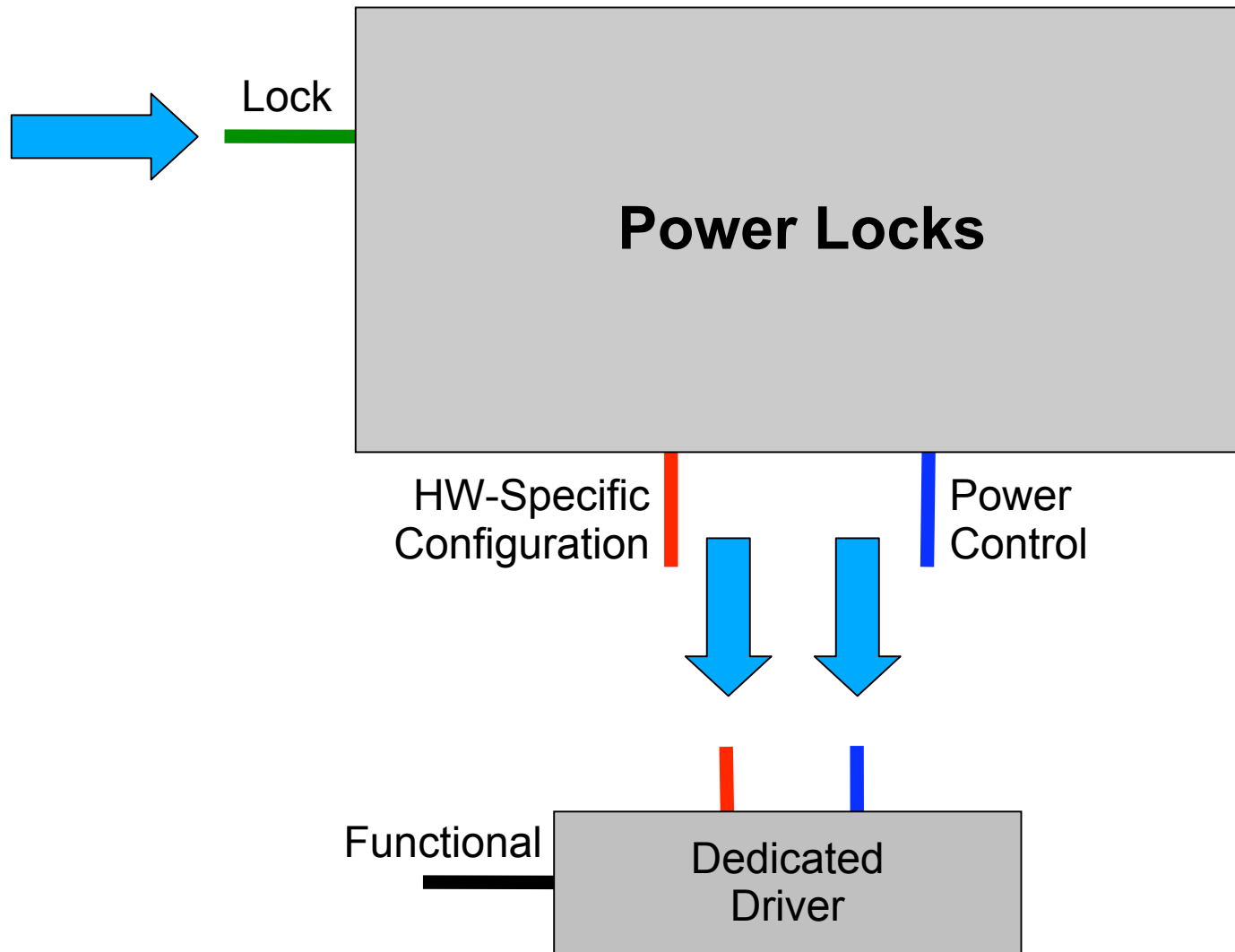

Power Locks

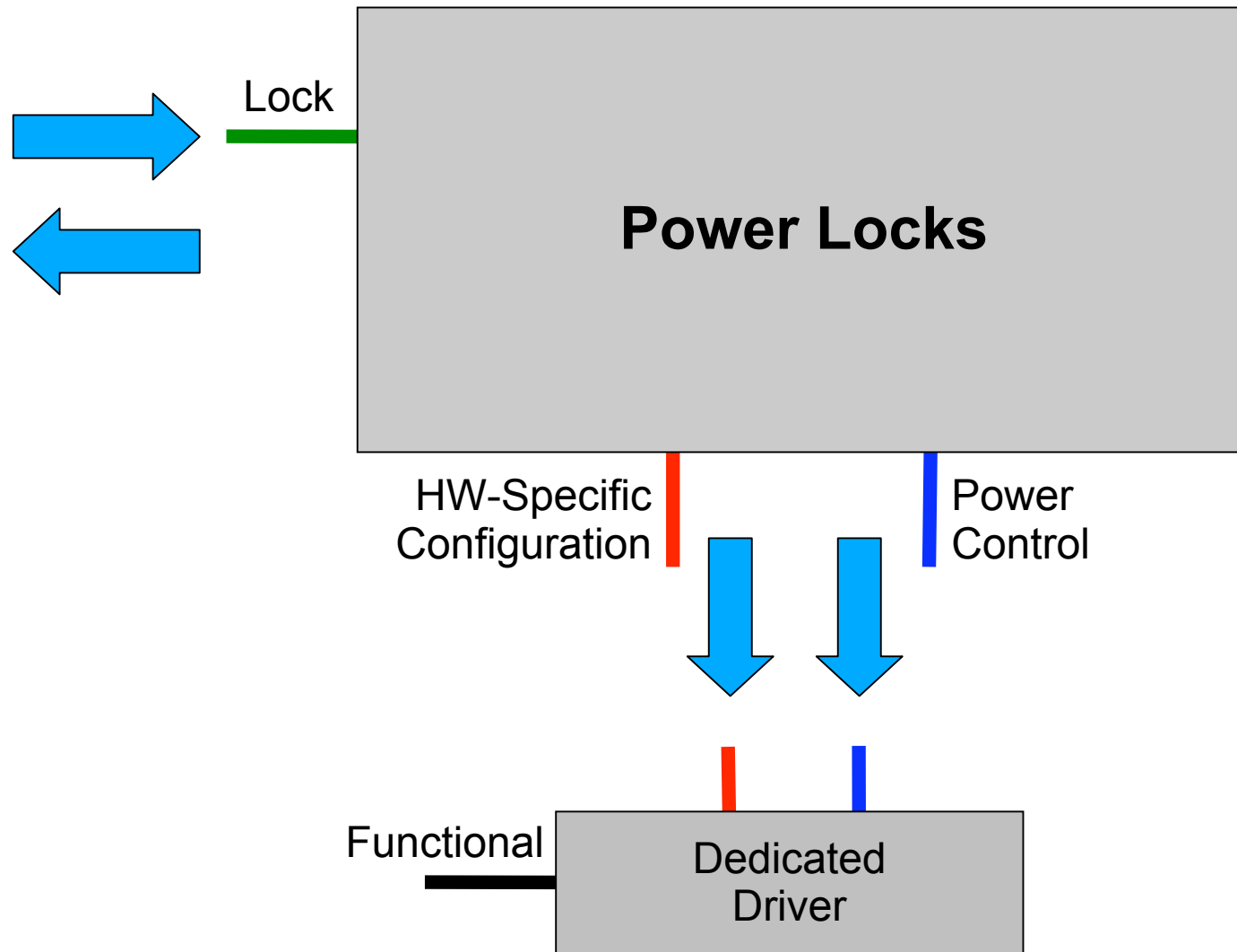

Power Locks

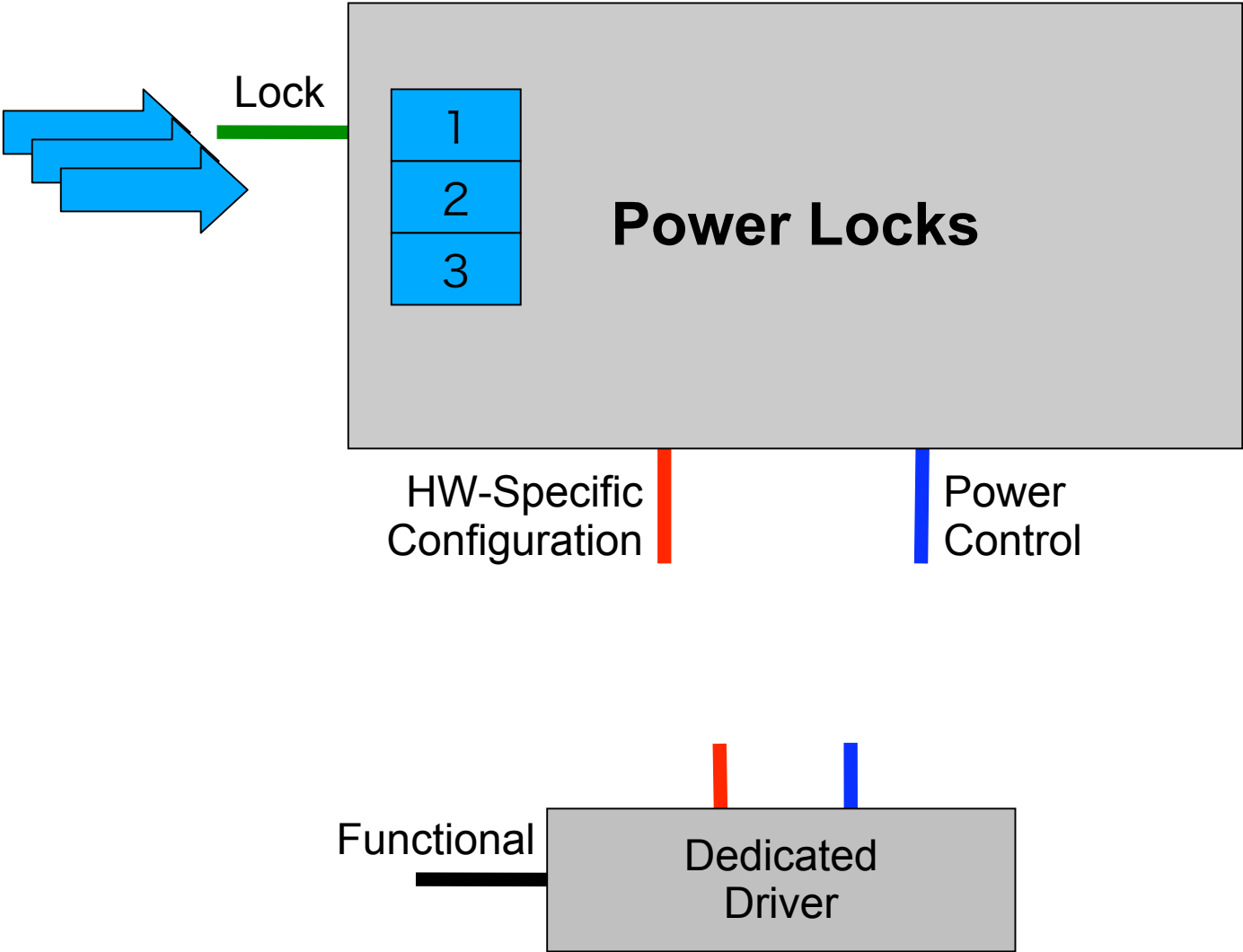

Power Locks

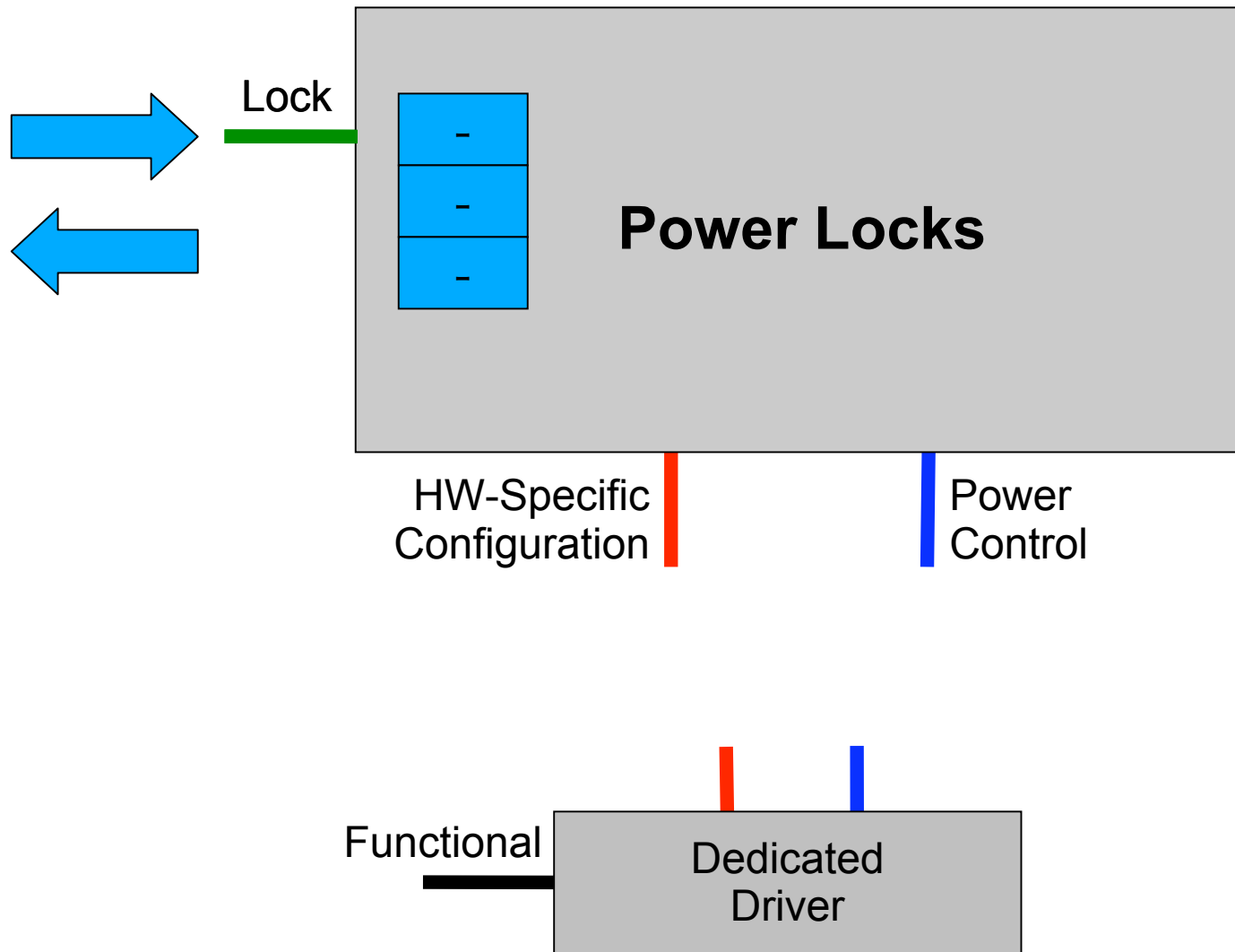

Power Locks

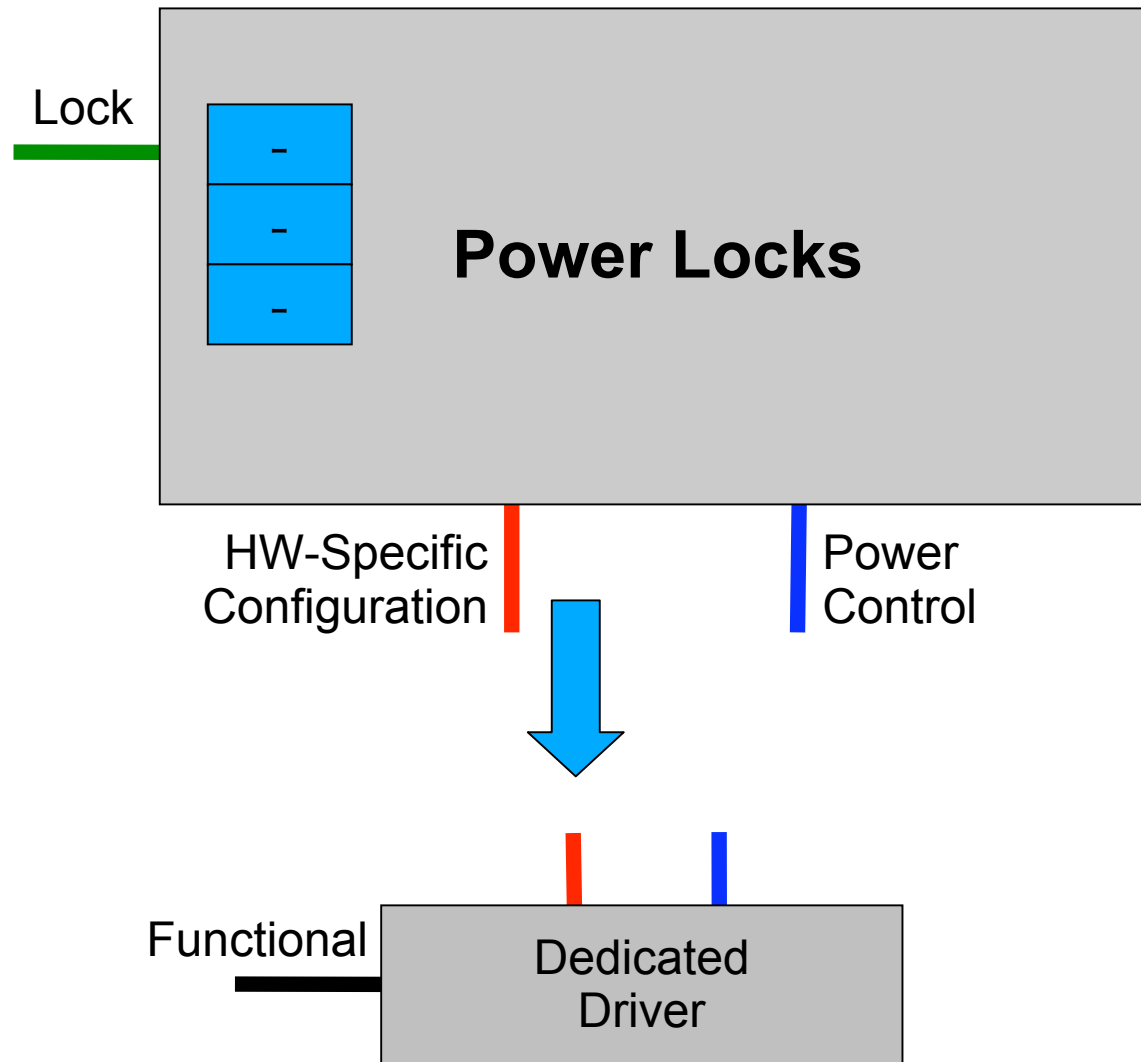

Power Locks

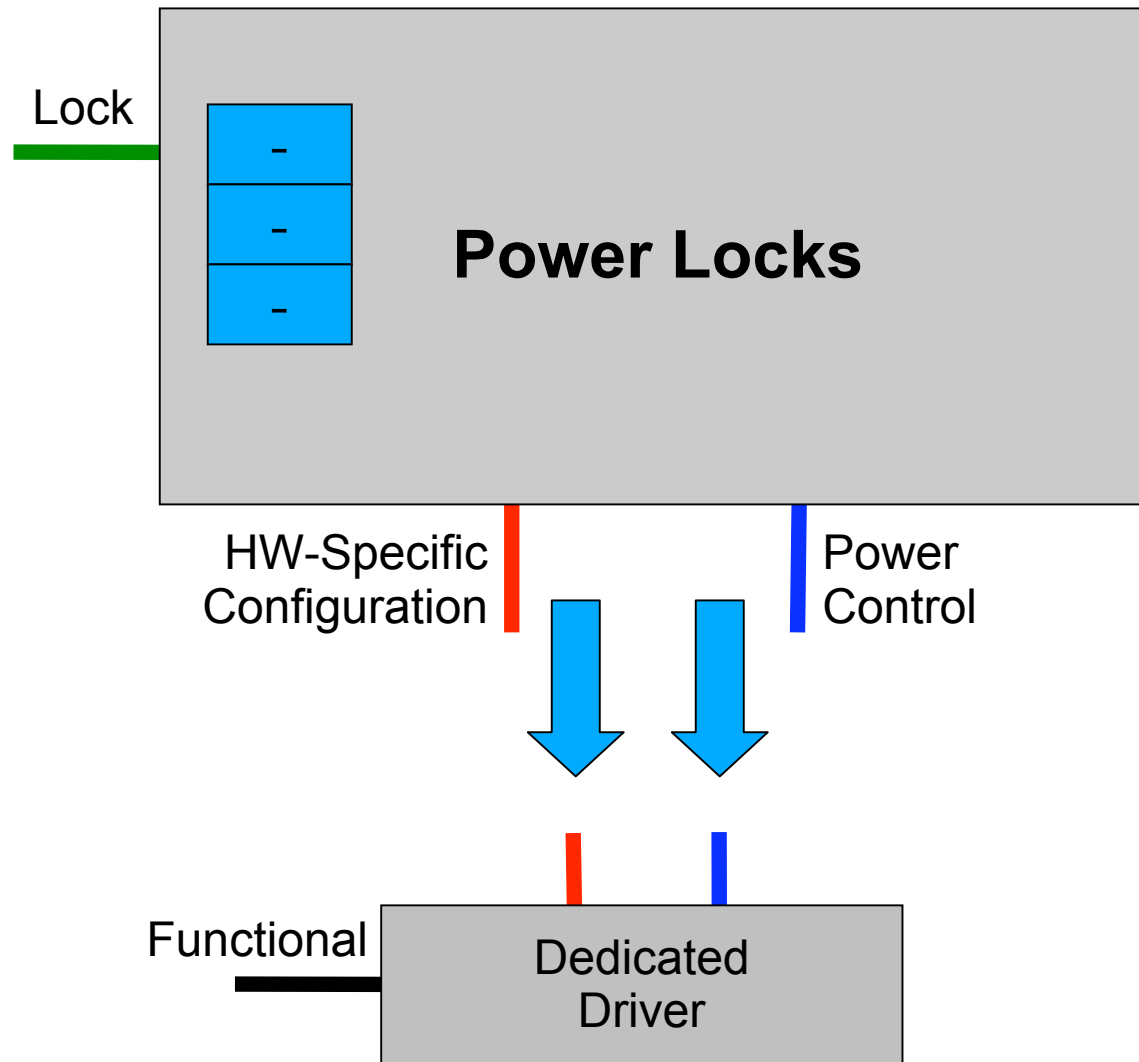

ICEM Architecture

- Defines three classes of drivers
 - ◆ Virtualized – provide only functional interface
 - ◆ Dedicated – provide functional and power interface
 - ◆ Shared – provide functional and lock interface
- *Power Locks*, split-phase locks with integrated energy and configuration management
- Component library
 - ◆ Arbiters – manage I/O concurrency
 - ◆ Configurators – setup device specific configurations
 - ◆ Power Managers – provide automatic power management

Component Library

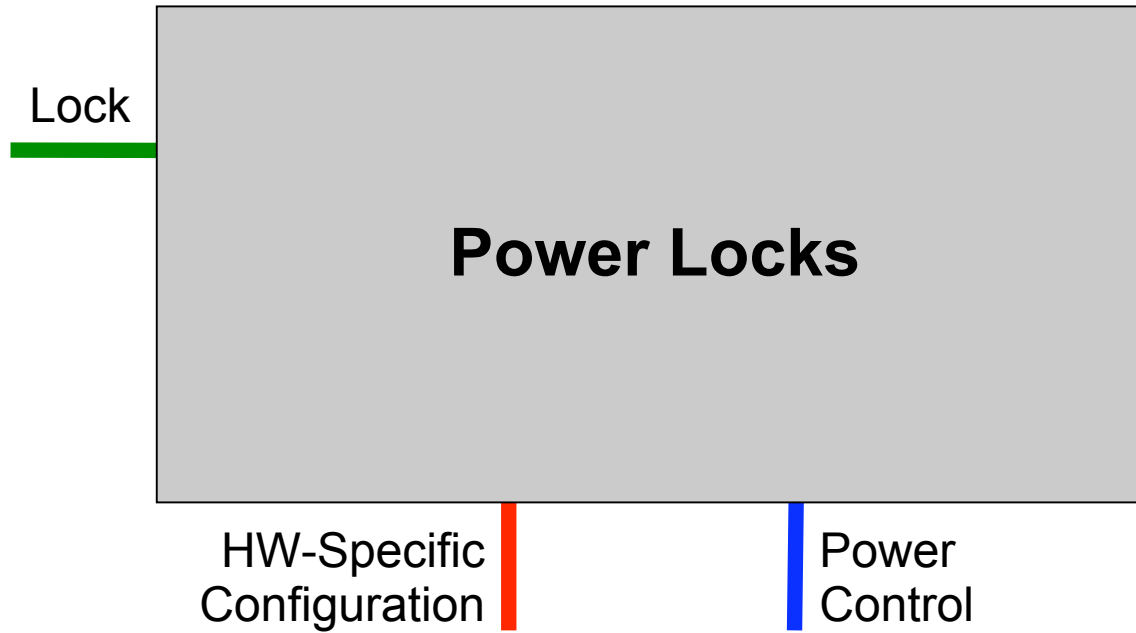

Component Library

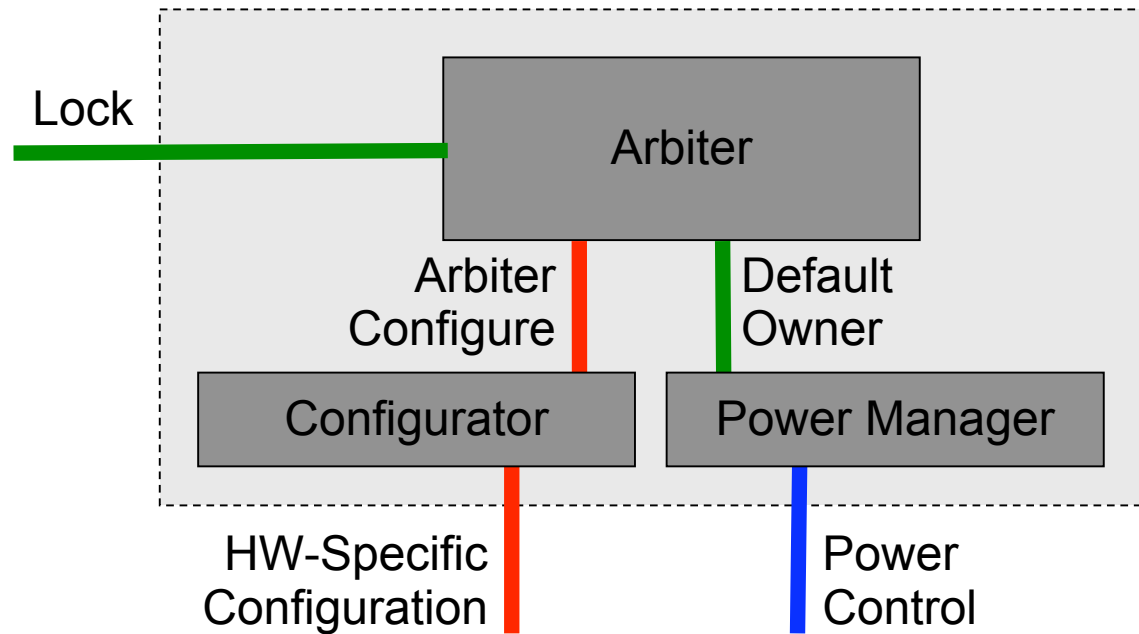

Component Library

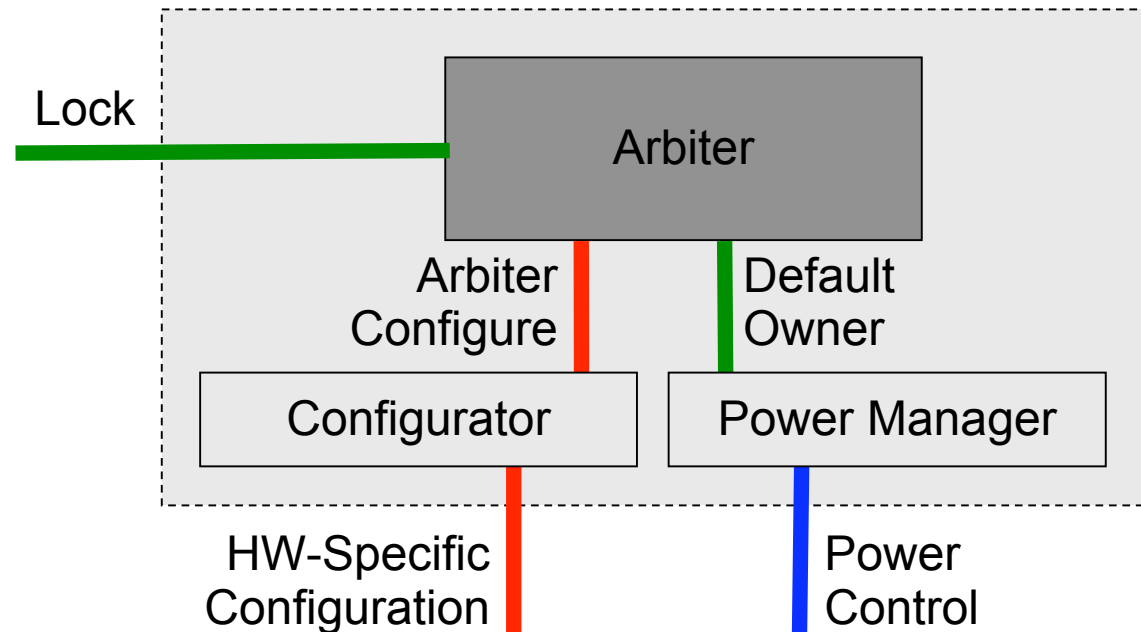

- **Lock** interface for concurrency control (FCFS, Round-Robin)
- **ArbiterConfigure** interface automatic hardware configuration
- **DefaultOwner** interface for automatic power management

Component Library

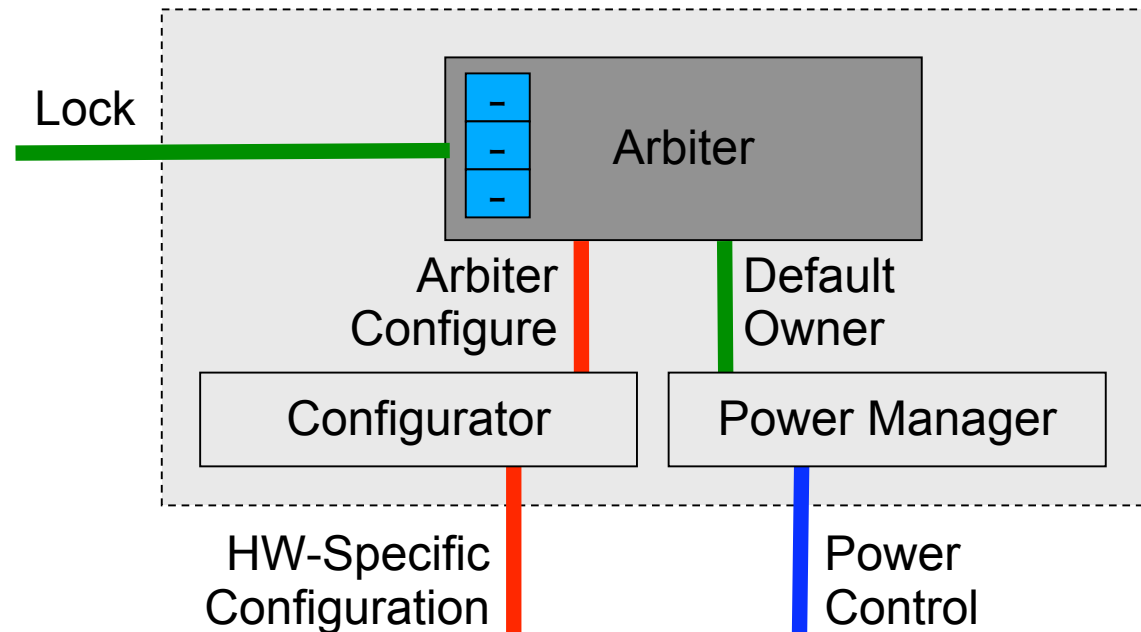

- **Lock** interface for concurrency control (FCFS, Round-Robin)
- **ArbiterConfigure** interface automatic hardware configuration
- **DefaultOwner** interface for automatic power management

Component Library

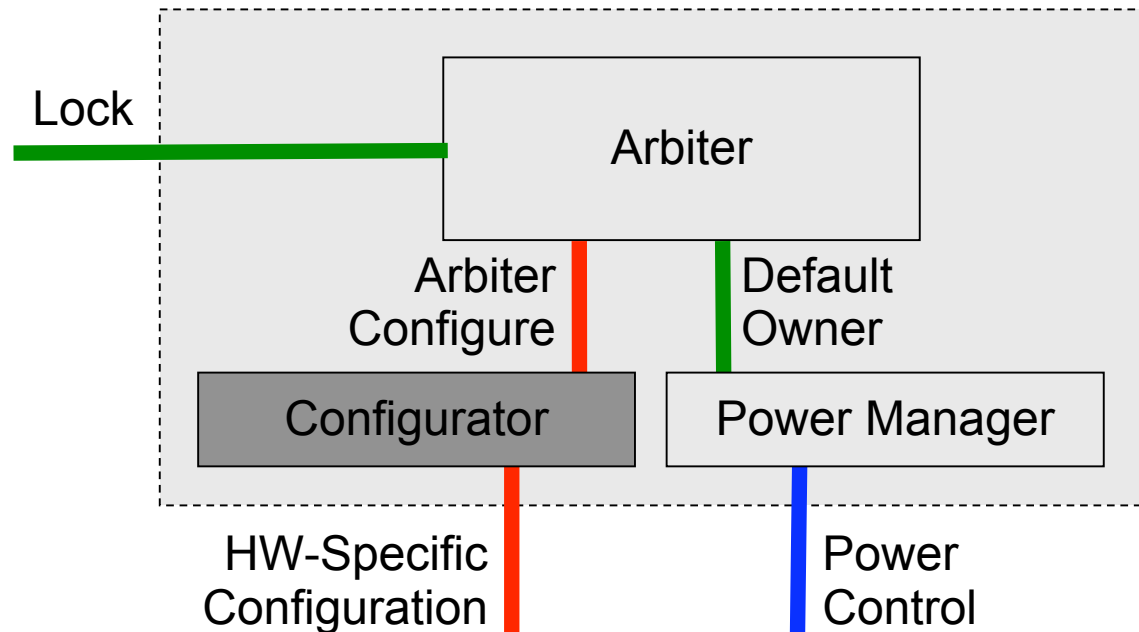

- Implement **ArbiterConfigure** interface
- Call hardware specific configuration from dedicated driver

Component Library

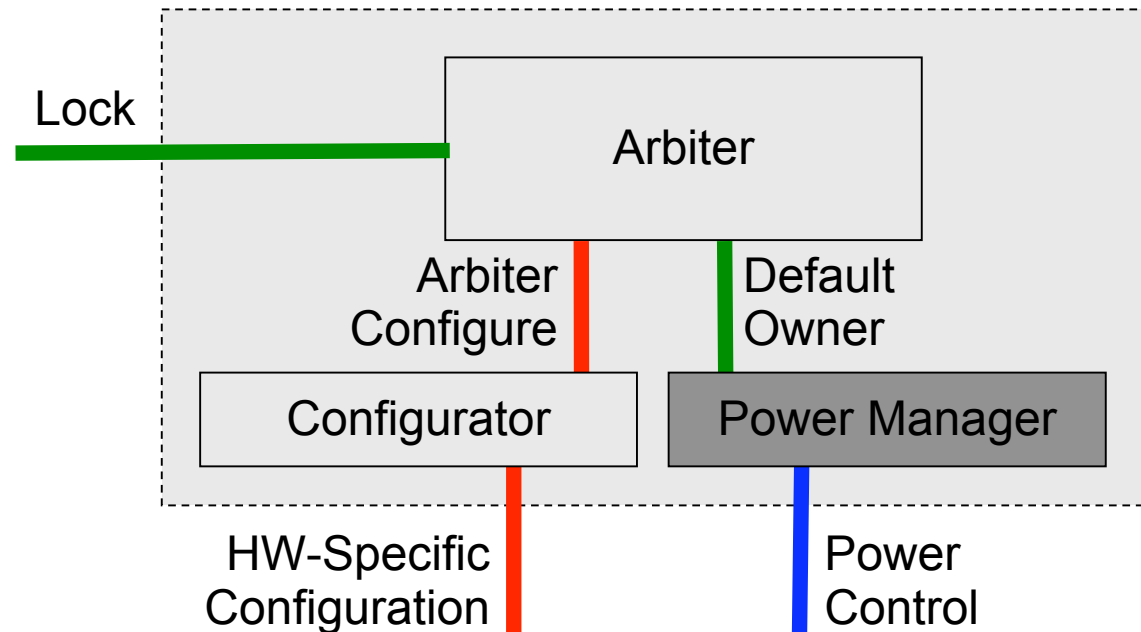

- Implement **DefaultOwner** interface
- Power down device when device falls idle
- Power up device when new lock request comes in
- Currently provide *Immediate* and *Deferred* policies

Shared Driver Example

- Msp430 USART (Serial Controller)
 - ◆ Three modes of operation – SPI, I²C, UART

Shared Driver Example

- Msp430 USART (Serial Controller)
 - ◆ Three modes of operation – SPI, I²C, UART

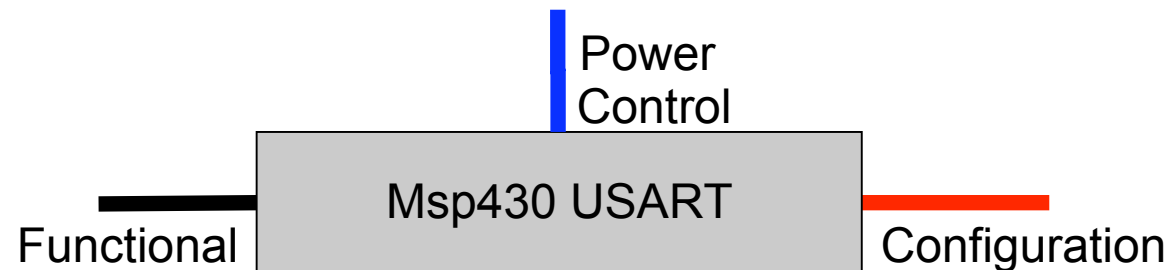

Shared Driver Example

- Msp430 USART (Serial Controller)
 - ◆ Three modes of operation – SPI, I²C, UART

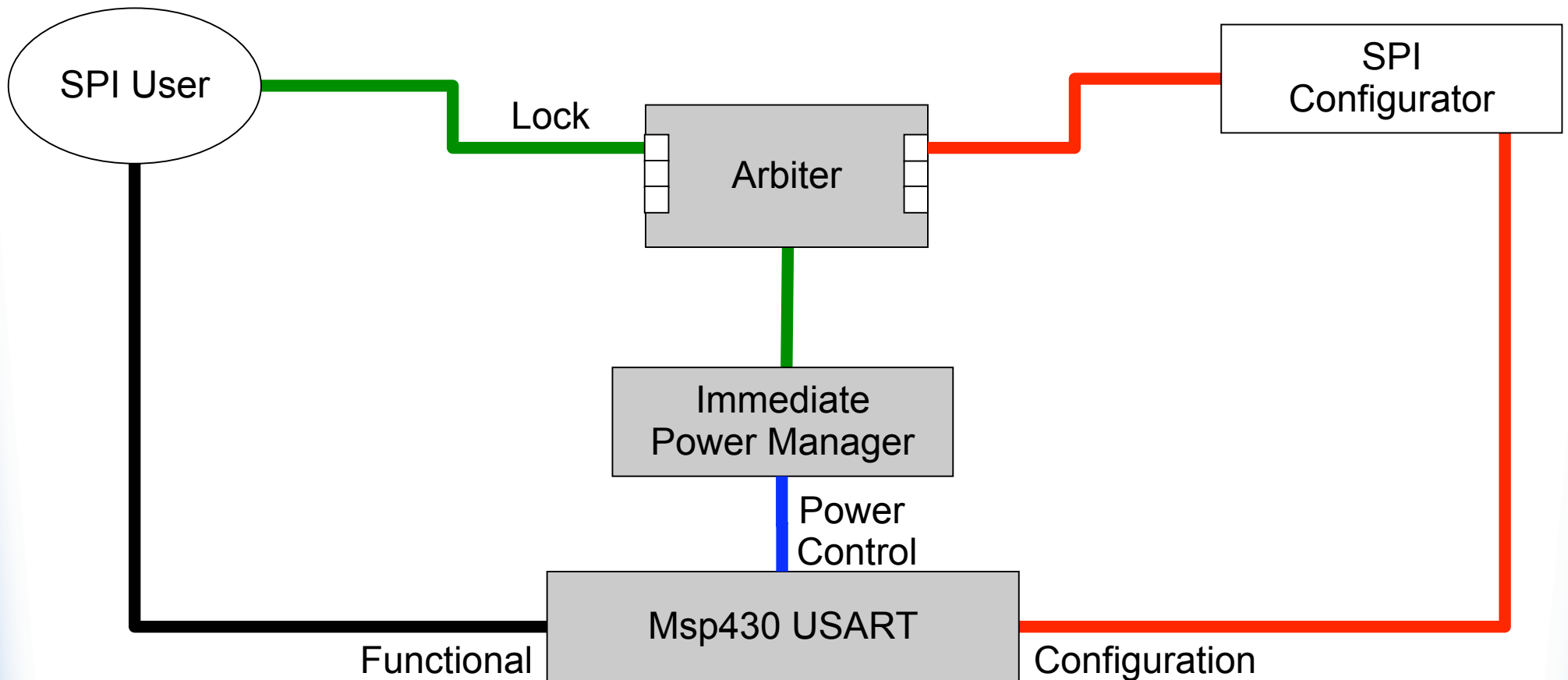

Shared Driver Example

- Msp430 USART (Serial Controller)
 - ◆ Three modes of operation – SPI, I²C, UART

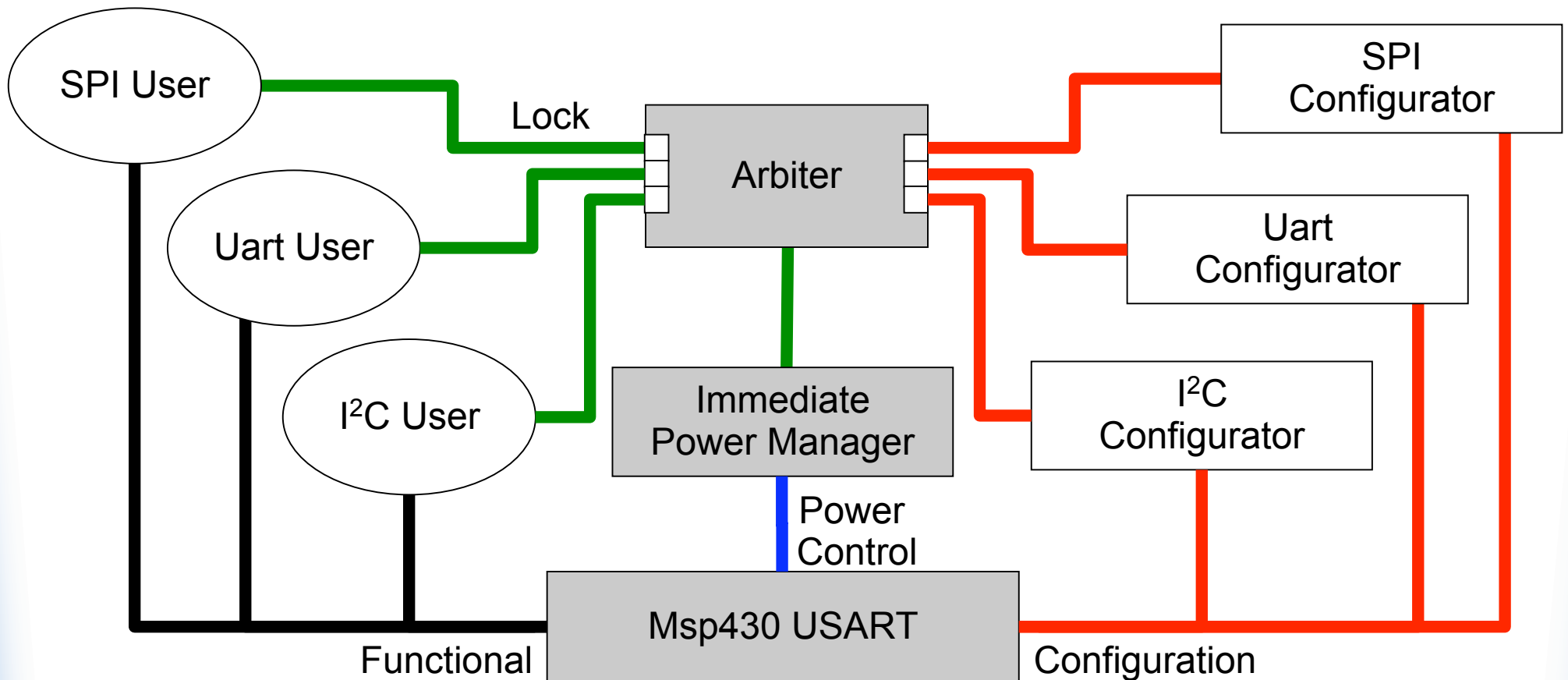

Virtualized Driver Example

- Flash Storage

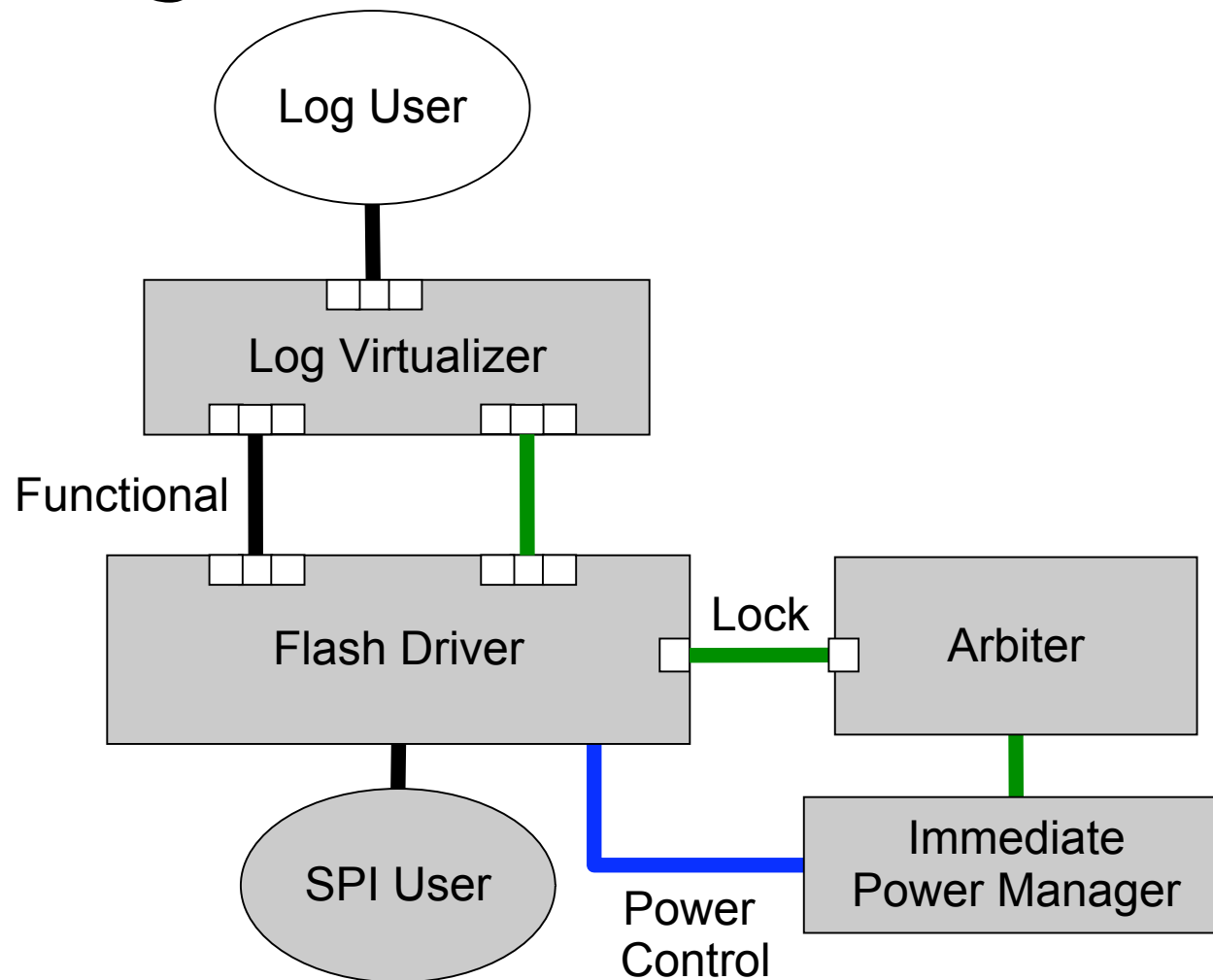

Virtualized Driver Example

- Flash Storage

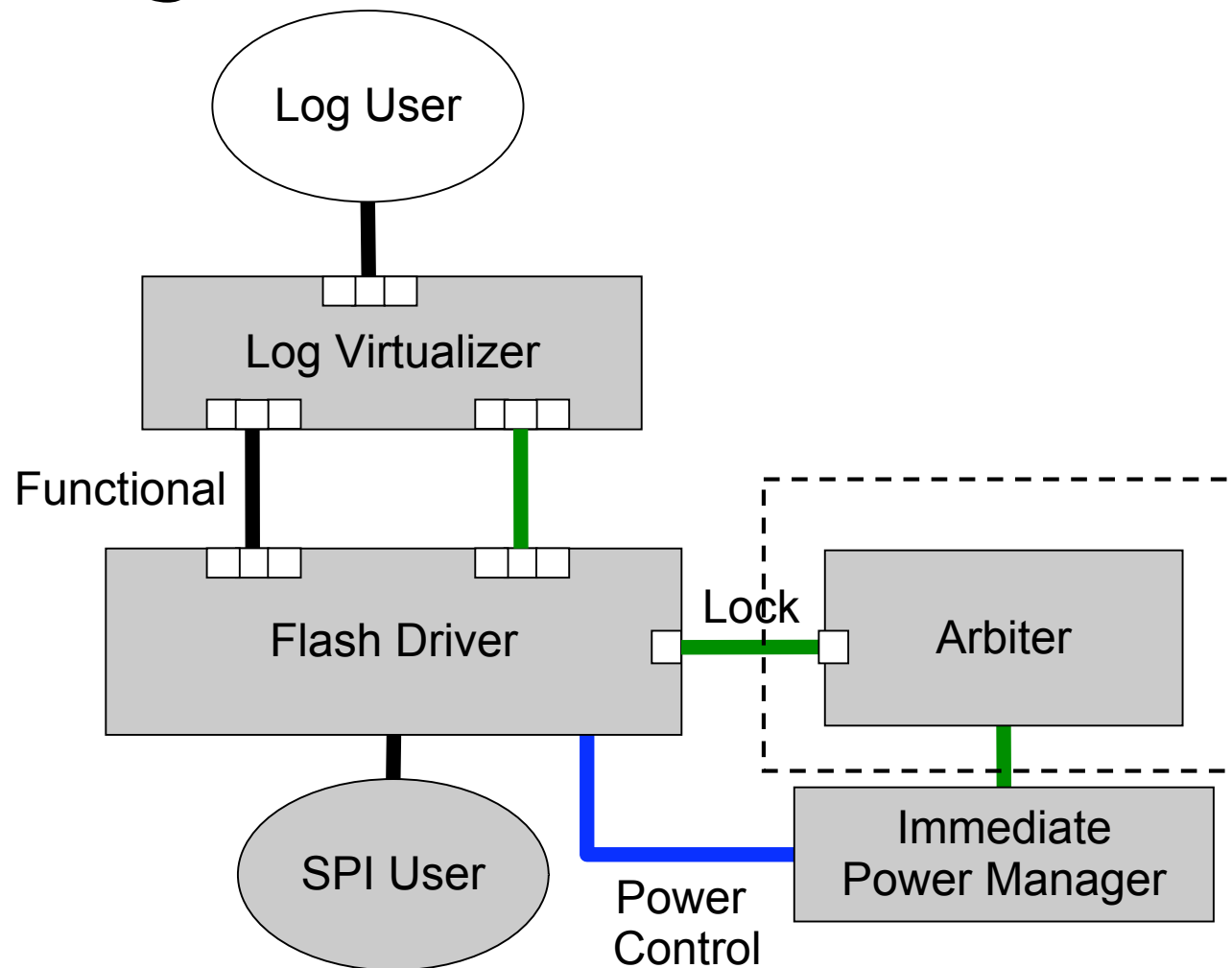

Virtualized Driver Example

- Flash Storage

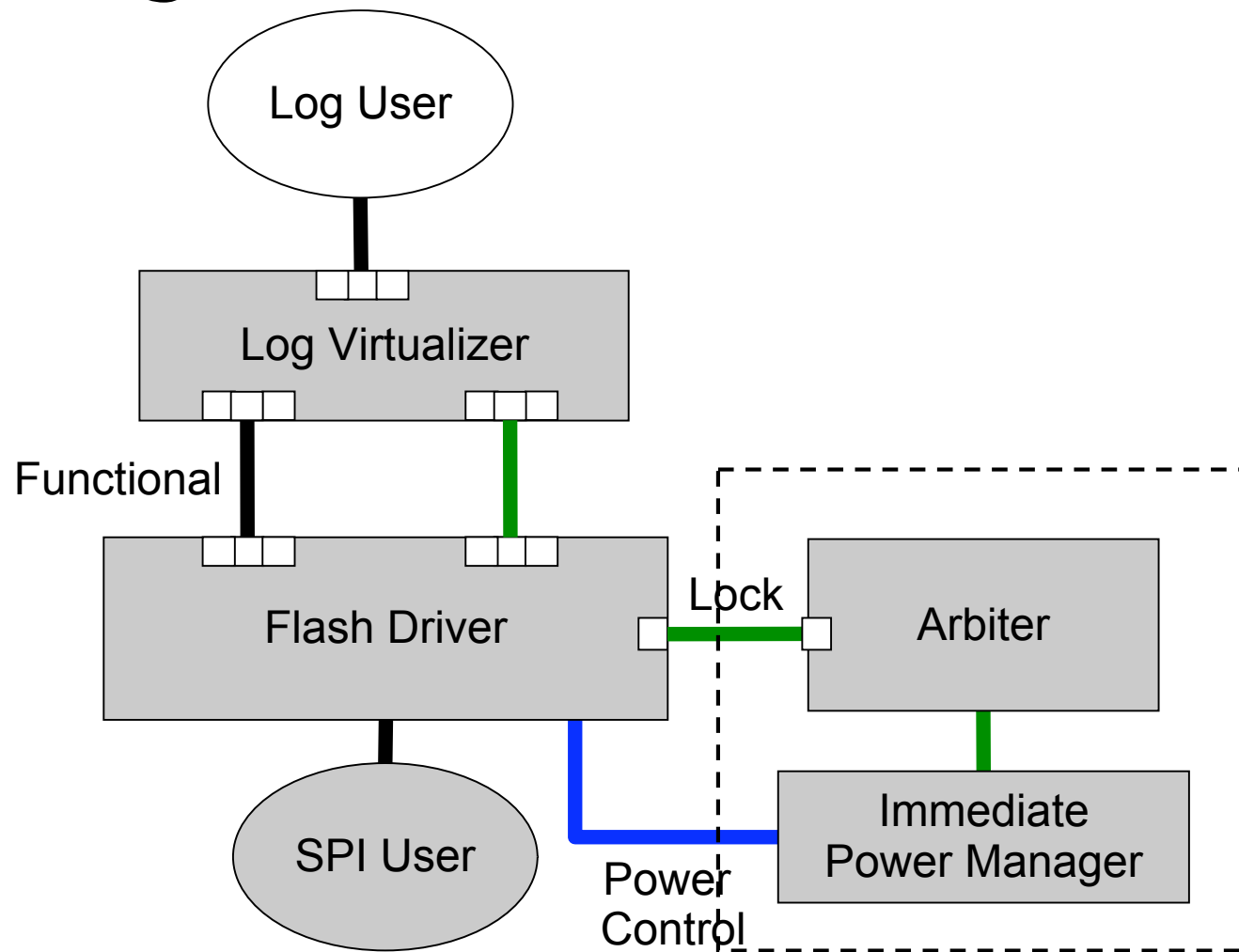

Virtualized Driver Example

- Flash Storage

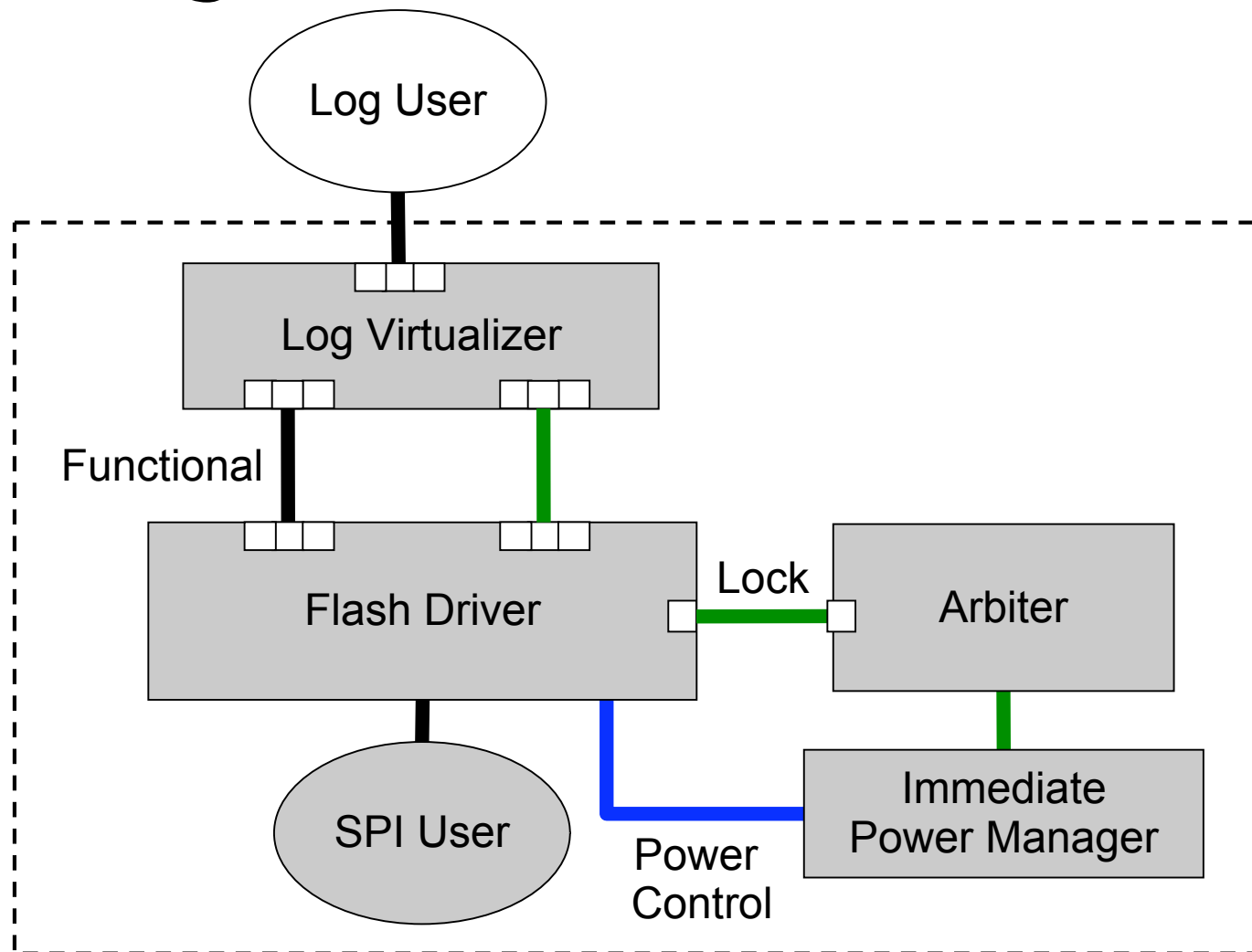

Virtualized Driver Example

- Flash Storage

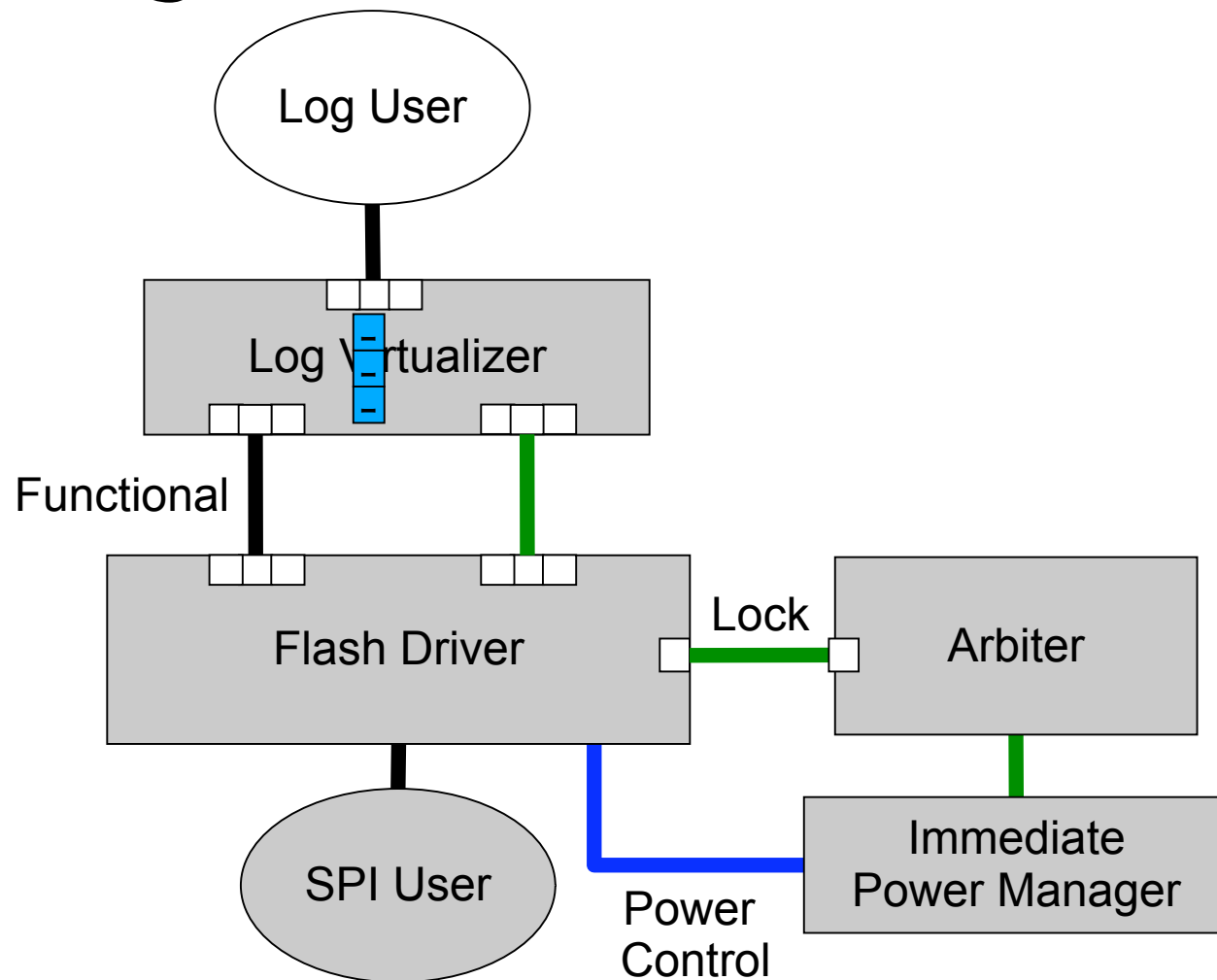

Virtualized Driver Example

- Flash Storage

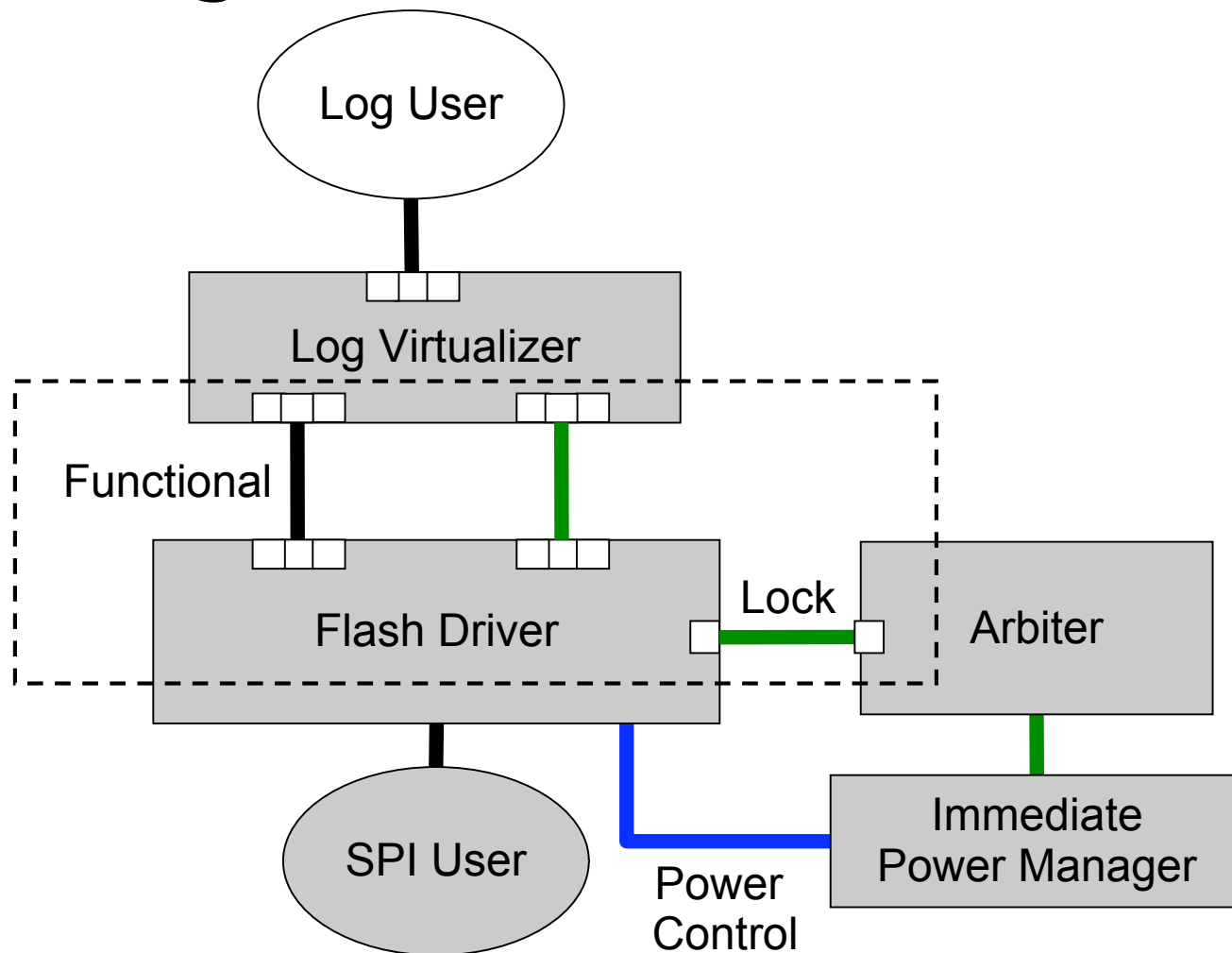

Virtualized Driver Example

- Flash Storage

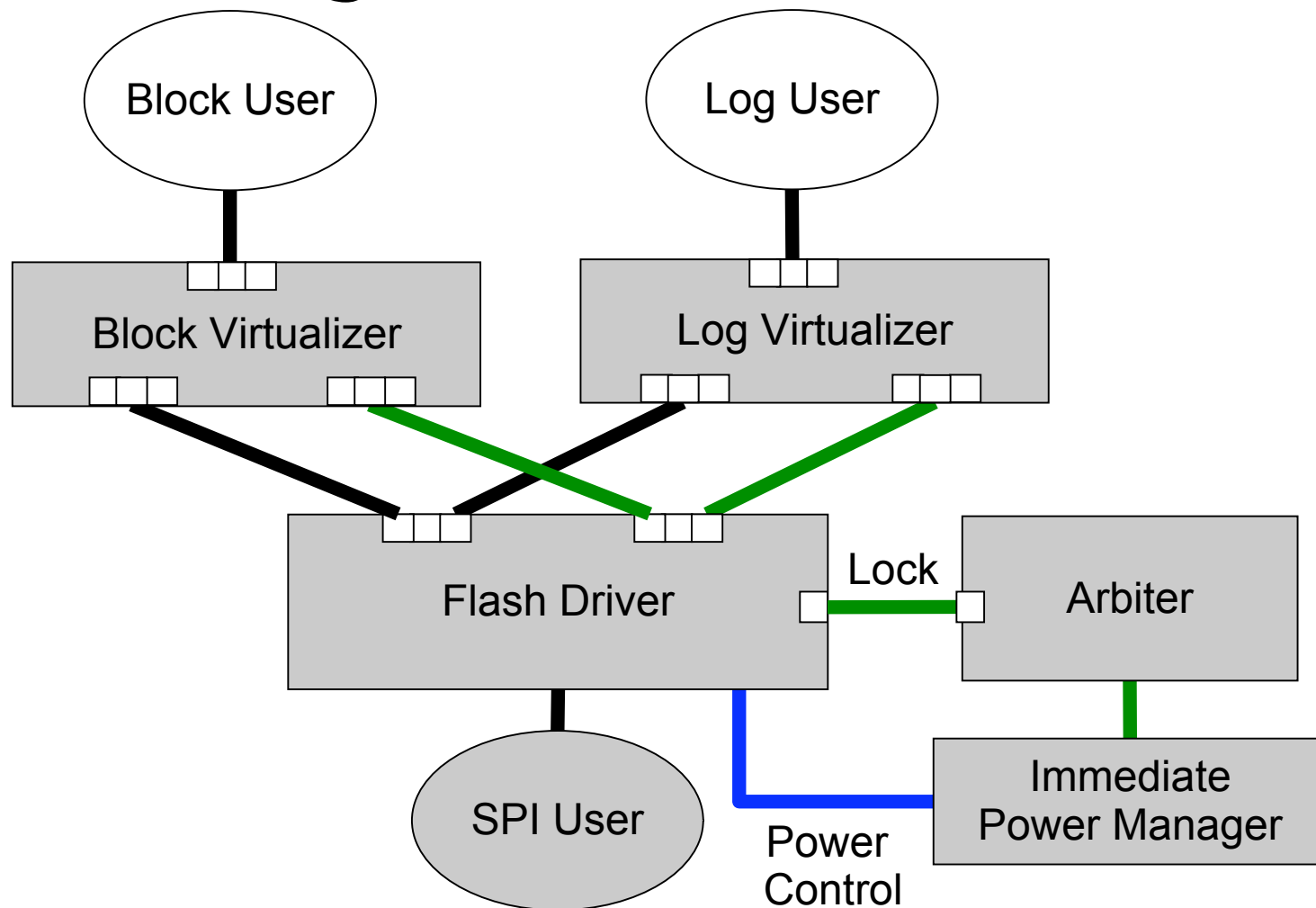

Virtualized Driver Example

- Flash Storage

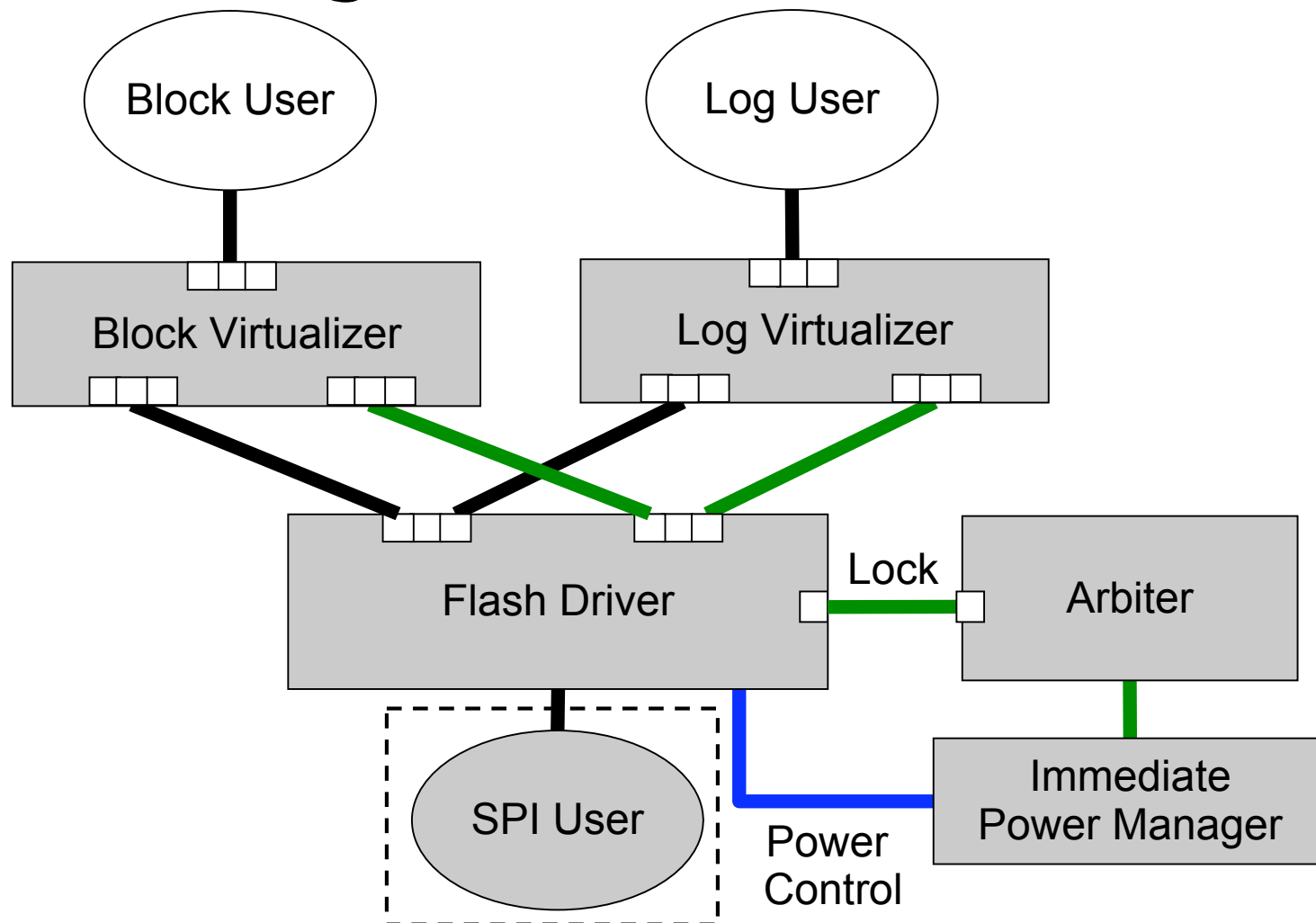

Outline

- Introduction and Motivation
- Platform and Application
- ICEM architecture
- **Evaluation**
- Conclusion

Applications

- Hand Tuned – Most energy efficient
- ICEM – All concurrent operations
- Serial + – Optimal serial ordering
- Serial – – Worst case serial ordering

Producer

Every 5 minutes:

Write prior samples
Sample photo active
Sample total solar
Sample temperature
Sample humidity

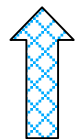

Sensors

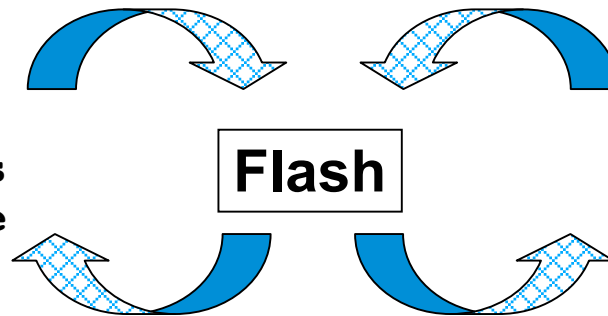

Flash

Consumer

Every 12 hours:

For all new entries:
Send current sample
Read next sample

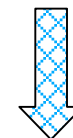

Radio

Tmote Energy Consumption

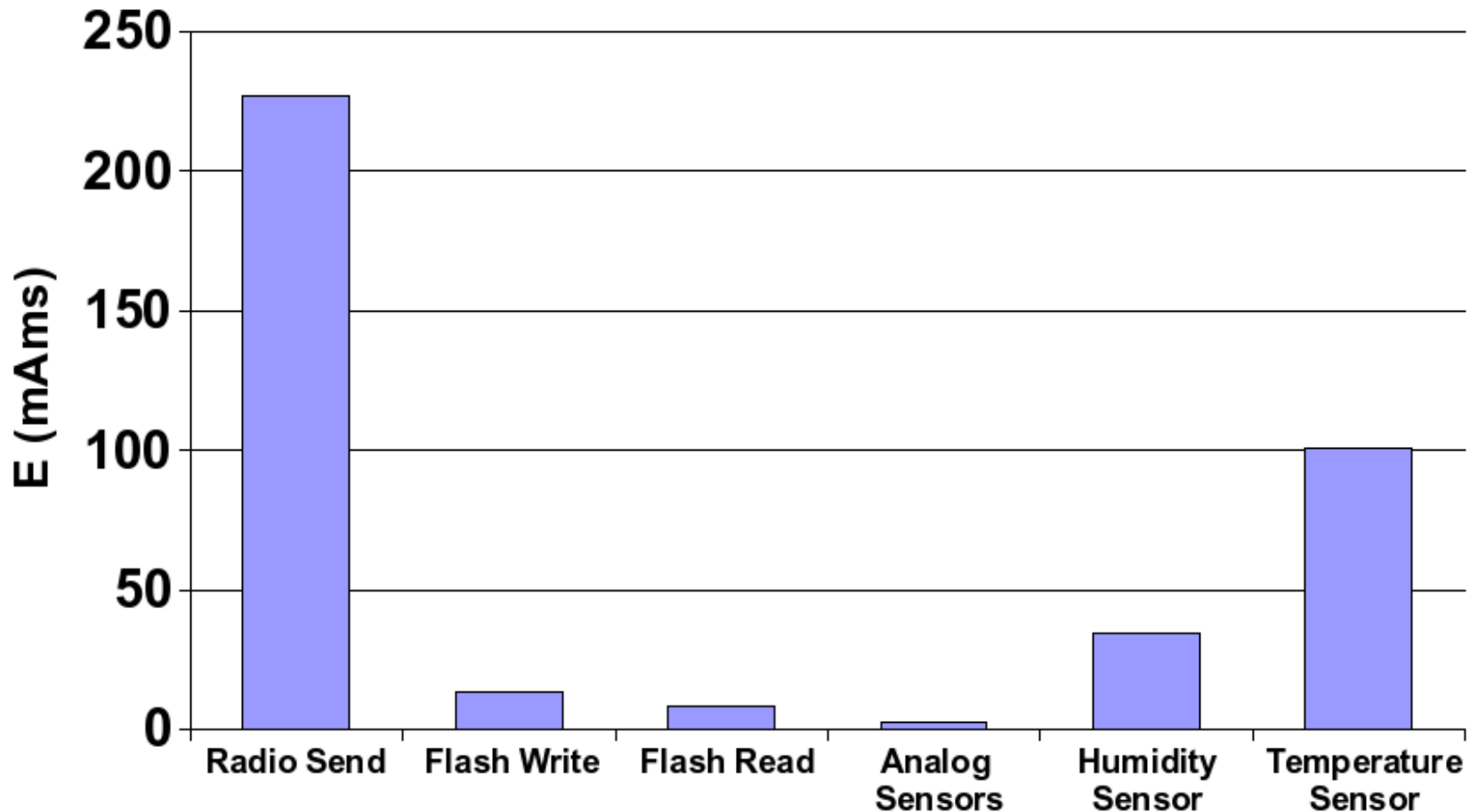

Average energy consumption for application operations

Tmote Energy Consumption

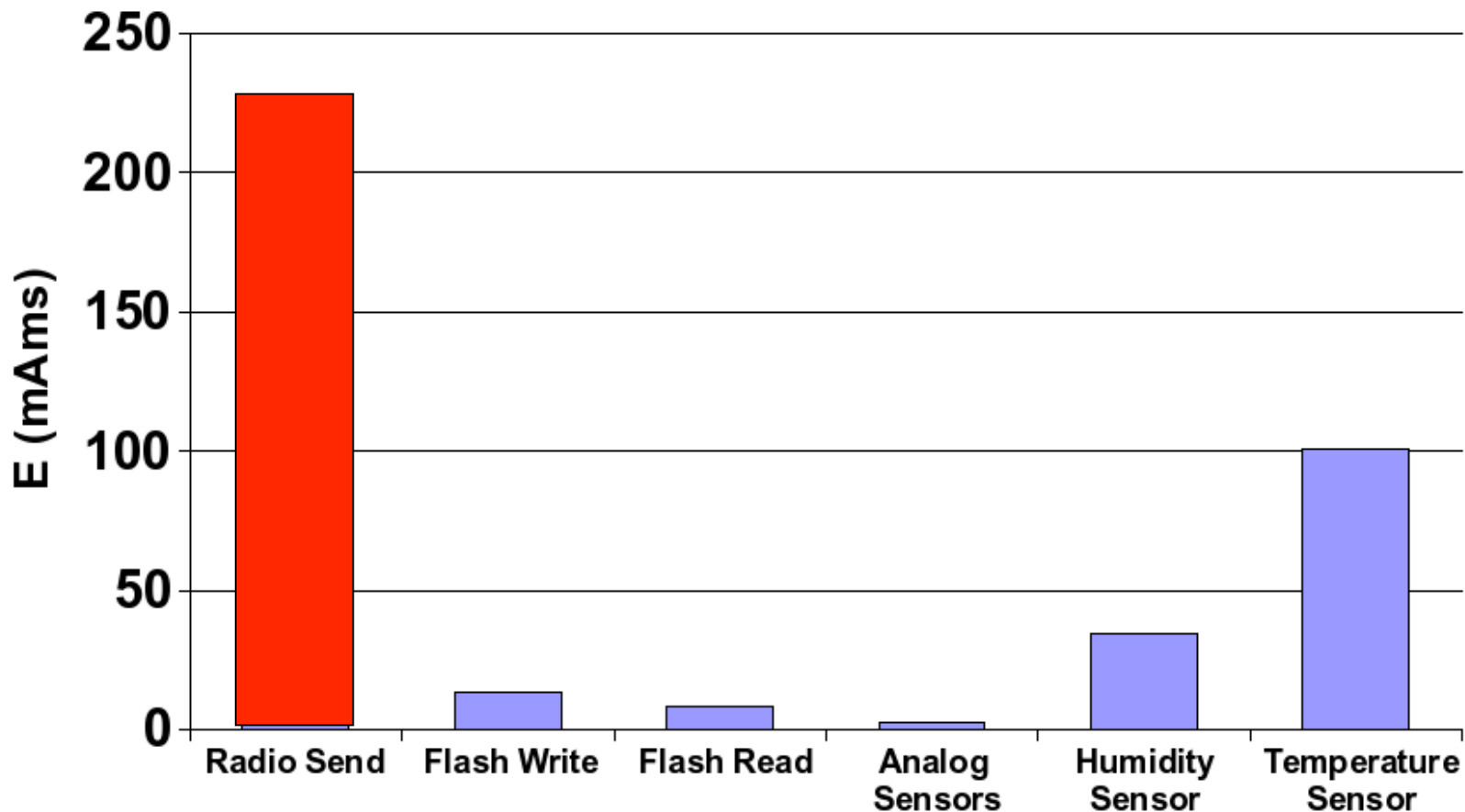

Average energy consumption for application operations

Application Energy Consumption

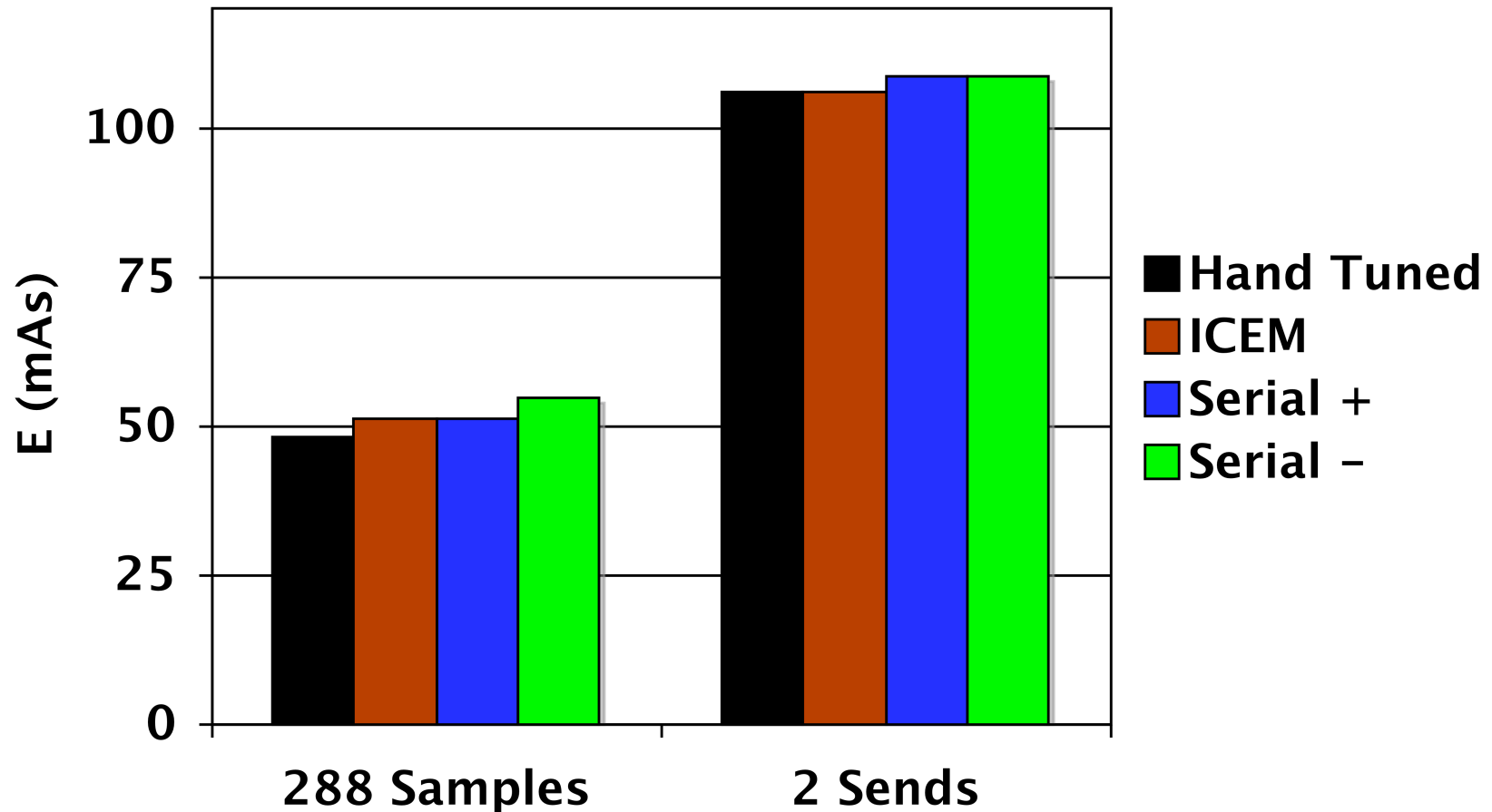

Application energy with 5 minute sampling interval and one send batch every 12 hours

Application Energy Consumption

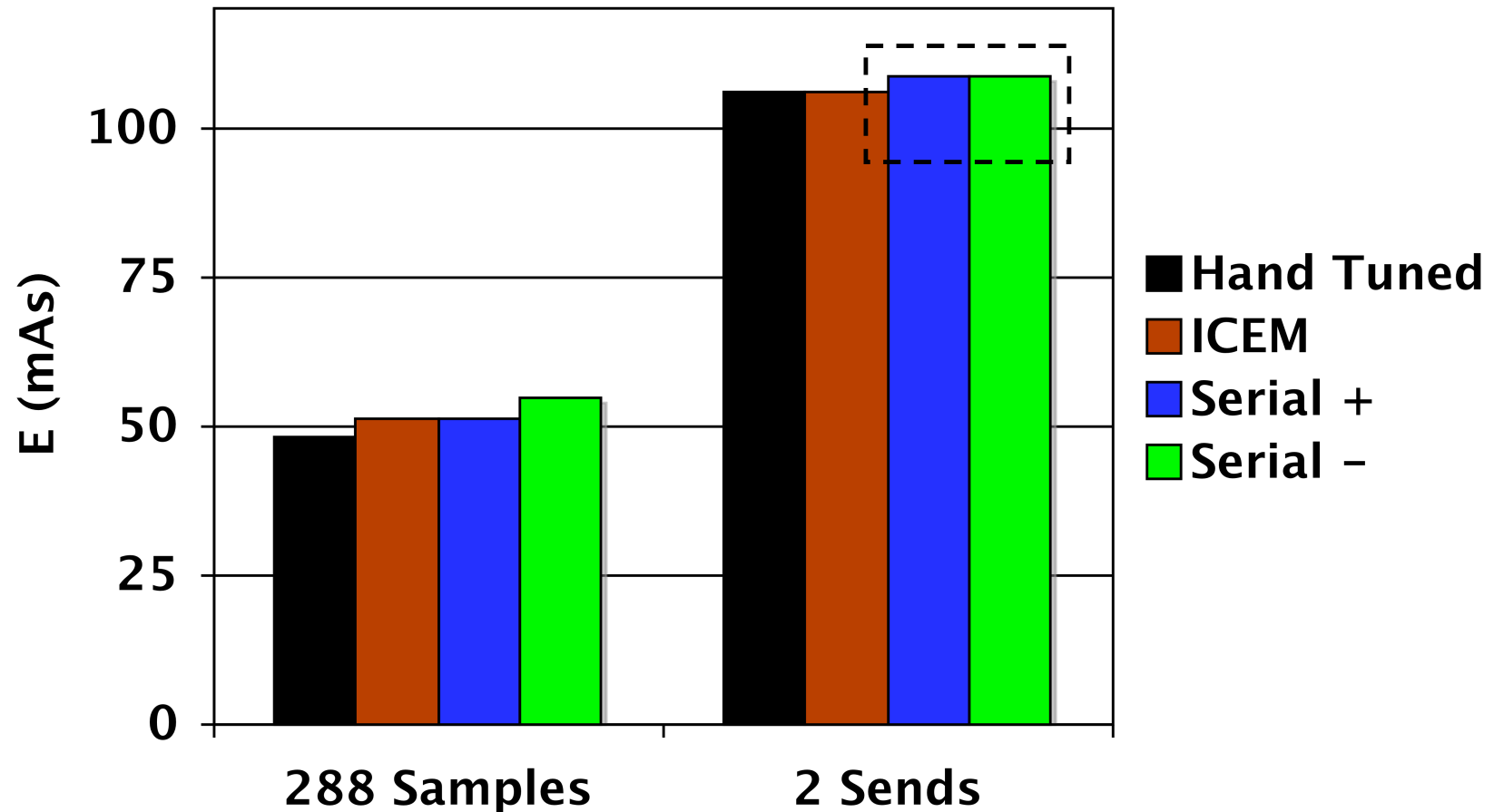

Application energy with 5 minute sampling interval and one send batch every 12 hours

Application Energy Consumption

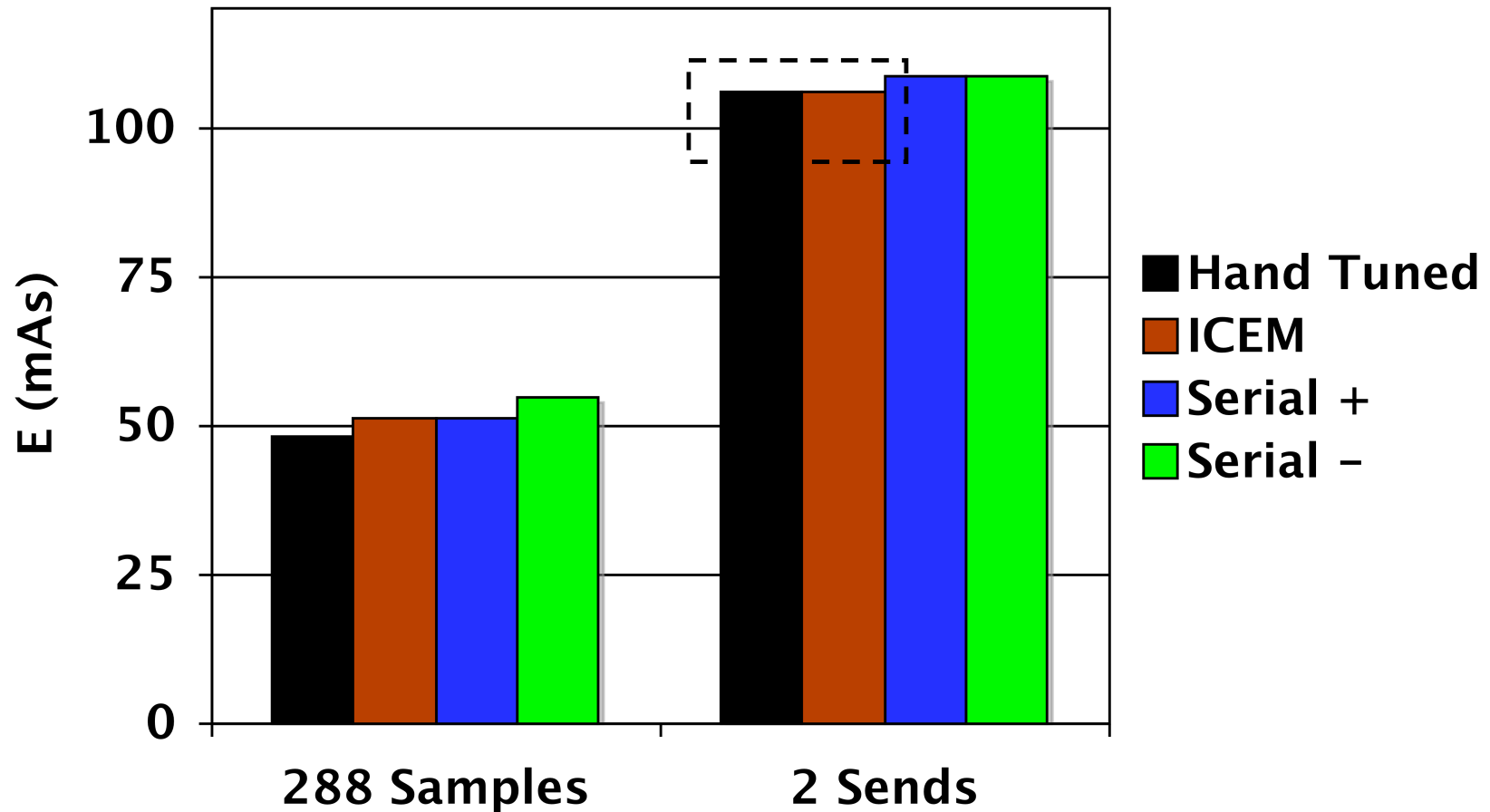

Application energy with 5 minute sampling interval and one send batch every 12 hours

Sampling Power Trace

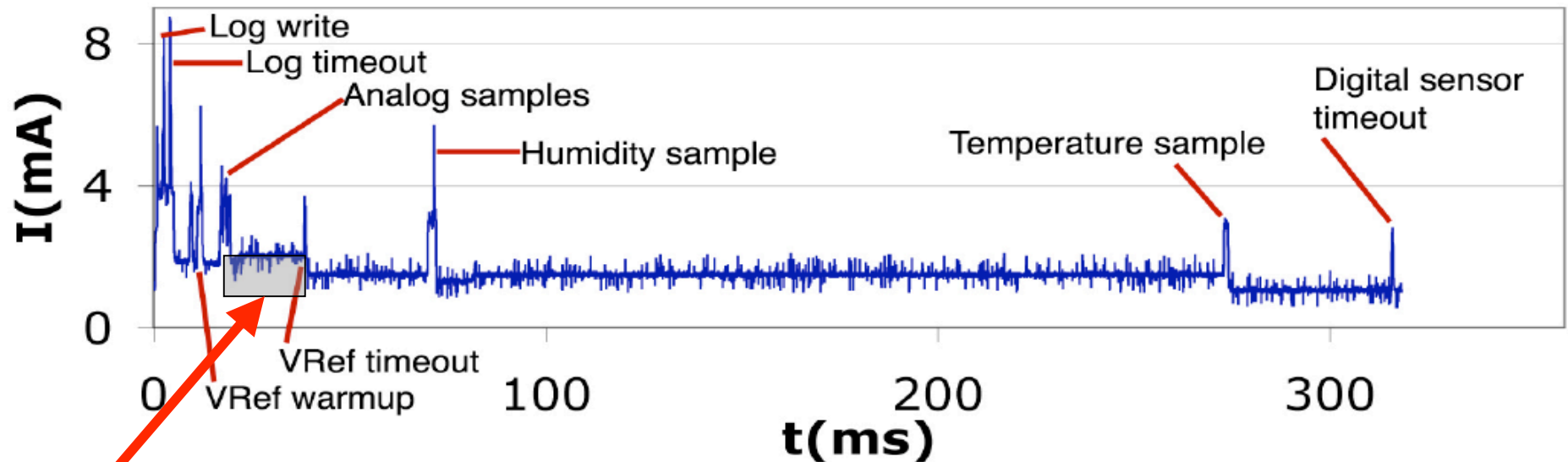

Overhead of ICEM to Hand-Tuned Implementation

= ADC Timeout + Power Lock Overheads

With 288 samples per day

≈ 2.9 mAs/day

≈ **1049 mAs/year**

Insignificant compared to total

5.60% of total sampling energy

0.03% of total application energy

Expected Node Lifetimes

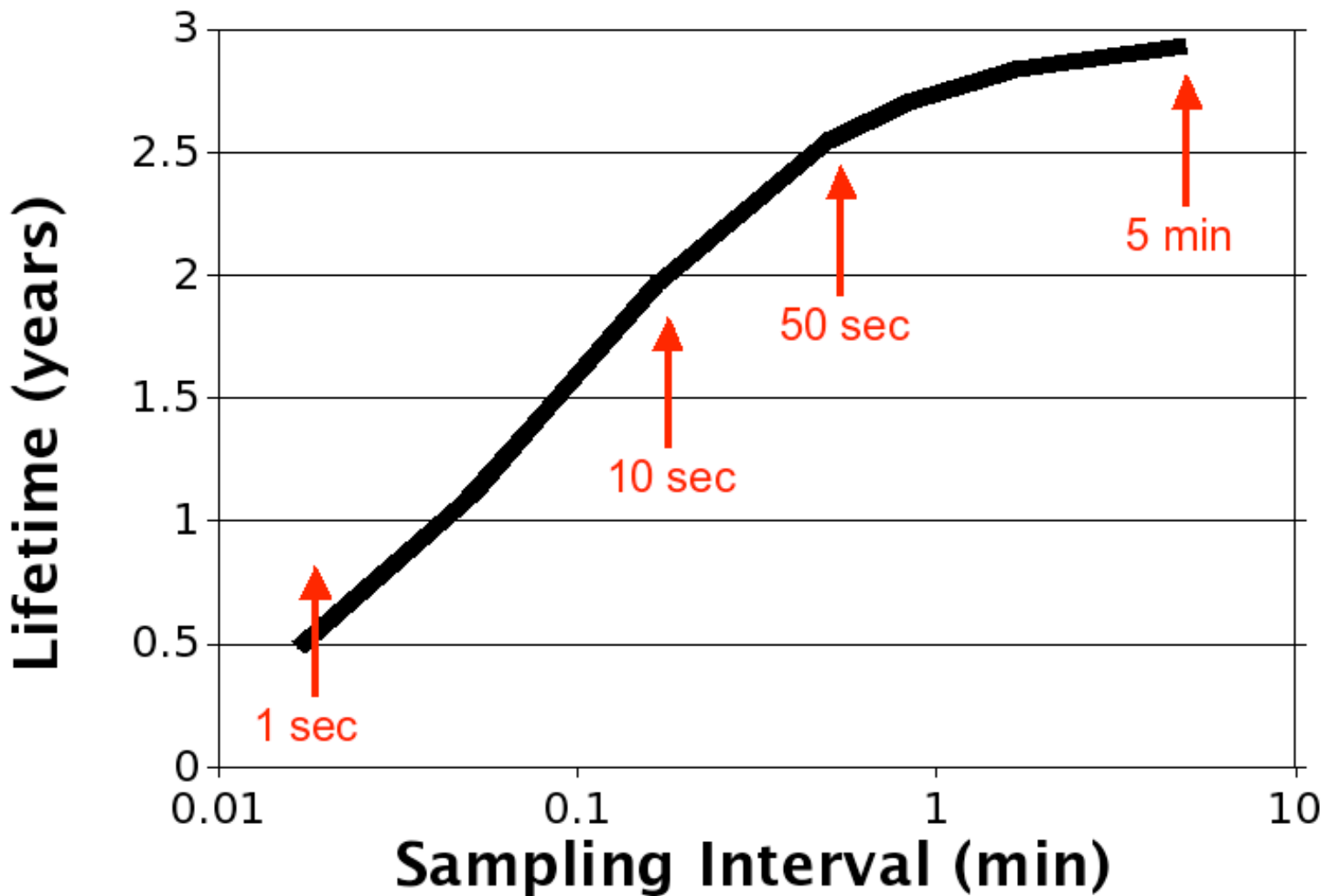

Expected Node Lifetimes

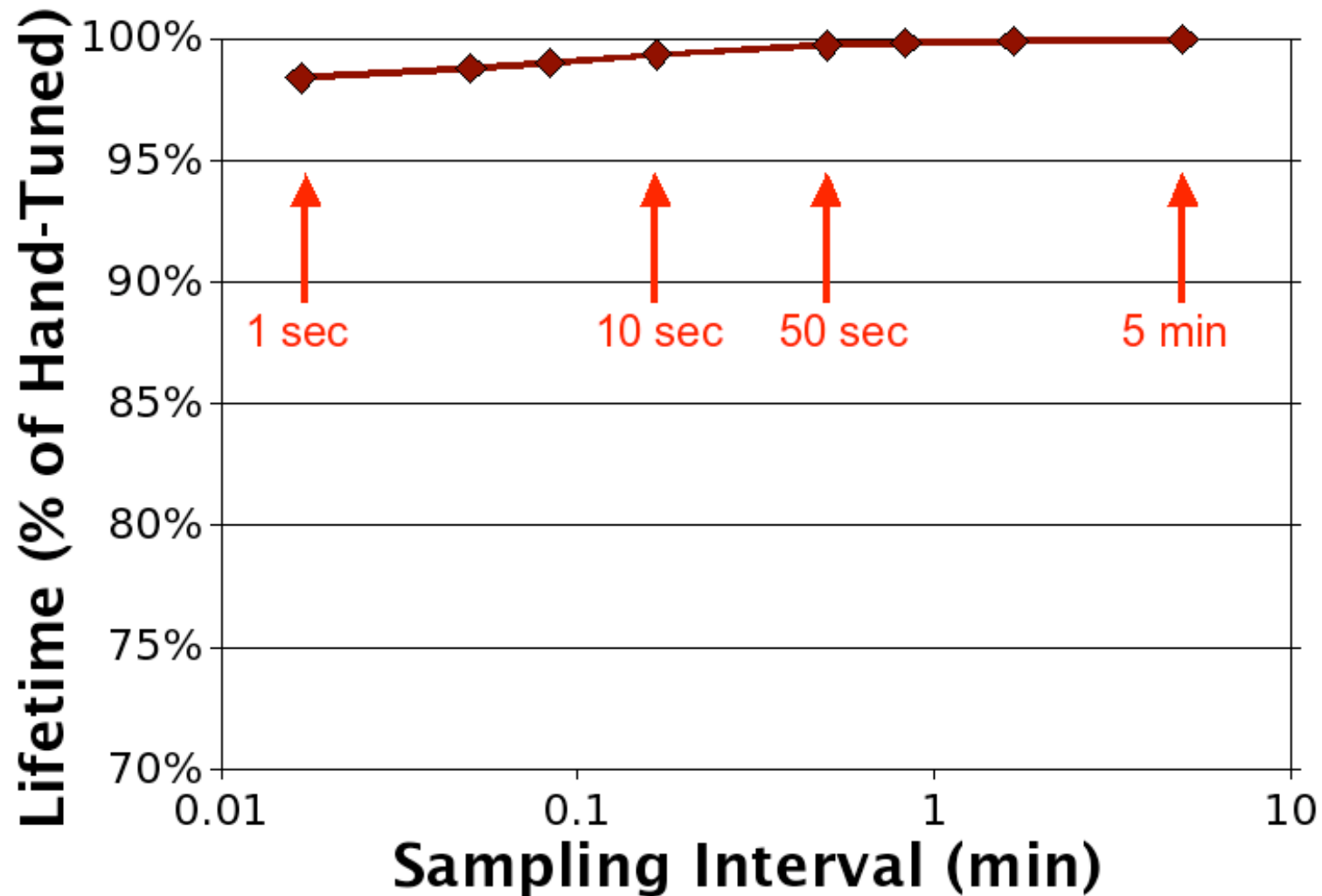

Expected Node Lifetimes

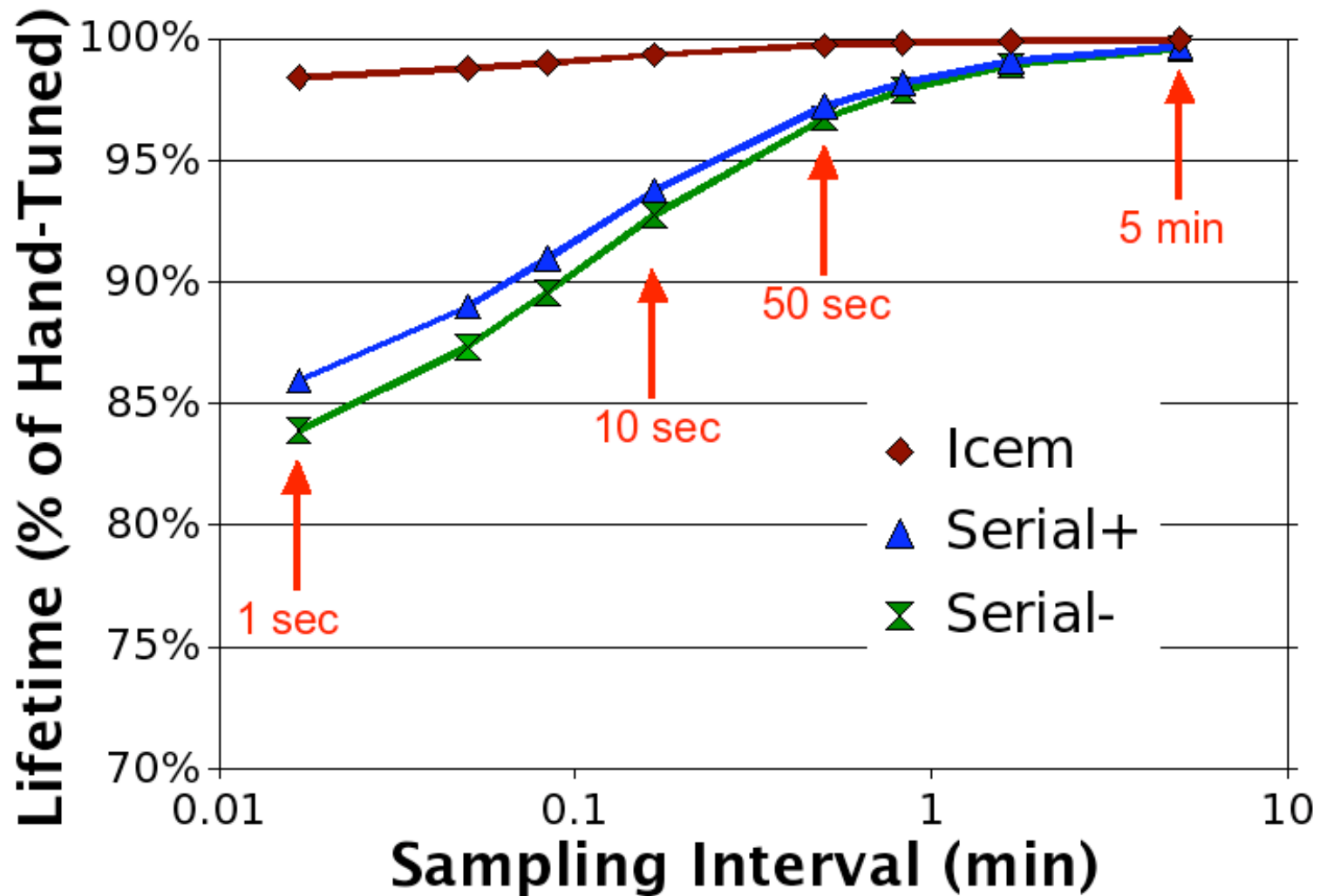

Evaluation Conclusions

- **Conclusions about the OS**
 - ◆ Small RAM/ROM overhead
 - ◆ Small computational overhead
 - ◆ Efficiently manages energy when given enough information
- **Conclusions for the developer**
 - ◆ Build drivers short power down timeouts
 - ◆ Submit I/O requests in parallel

Conclusion

- **ICEM:** Integrated Concurrency and Energy Management
 - ◆ Device driver architecture for low power devices
 - ◆ At least 98.4% as energy efficient as hand-tuned implementation of representative application
 - ◆ Simplifies application and driver development
 - ◆ Questions the assumption that applications must be responsible for all energy management and cannot have a standardized OS with a simple API

Questions?



TKN

**Telecommunication
Networks Group**



ARCHROCK

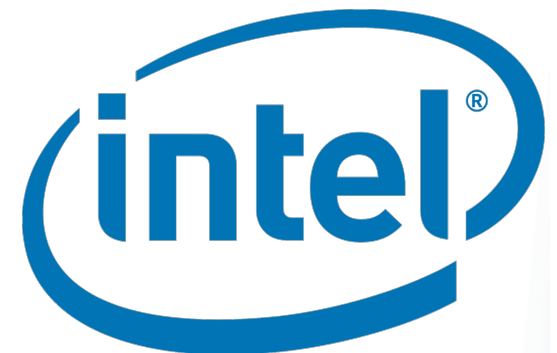

Questions?

- SourceForge TinyOS CVS repository:
 - ◆ http://sourceforge.net/cvs/?group_id=28656
- Library components and interfaces
 - ◆ [tinyos-2.x/tos/interfaces](#)
 - ◆ [tinyos-2.x/tos/lib/power](#)
 - ◆ [tinyos-2.x/tos/system](#)
- Example Drivers
 - ◆ Atmega128 ADC: [tos/chips/atm128/adc](#)
 - ◆ MTS300 Photo: [tos/sensorboards/mts300](#)
 - ◆ MSP430 USART0: [tos/chips/msp430/usart](#)
 - ◆ Storage: [tos/chips/stm25p](#)
 - ◆ CC2420: [tos/chips/cc2420](#)